

Pulse safety device with adaptive controller for technical systems with high reliability requirements

K S Terasmes¹, E A Petrovsky¹, K A Bashmur¹, V S Tynchenko^{1,2} and V V Kukartsev^{1,2}

¹ Siberian Federal University, 79, Svobodny Av., Krasnoyarsk, 660041, Russia

² Reshetnev Siberian State University of Science and Technology, 31 Krasnoyarsky Rabochy Av., Krasnoyarsk, 660037, Russia

E-mail: terasmes@yandex.ru, bashmur@bk.ru

Abstract. To ensure the protection of technical systems against excessive pressure, pulse-safety devices (pilot-operated relief valves, or PORV) are used, which differ from spring-loaded safety valves in their increased throughput and high accuracy of operation at set pressures. At the same time, PORVs are less reliable due to the complexity of the design. Their reliability depends on the operability of two valves - pulse and main ones. The pulse valve that controls the entire safety system is still the weakest PORV element. This is especially true for systems that have high safety and reliability requirements, for example, for aerospace technology and the nuclear industry, because the resource of sensitive elements decreases sharply when working in extreme operating conditions. The article proposes a PORV design with redundancy of the valve sensing element by a system in the form of a metal bellows and a slide valve. The reliability values of the standard and proposed PORV designs are analyzed.

1. Introduction

For complex technical systems used, for example, in the nuclear and aerospace industries, there are high requirements for reliability, due to the danger of processes (chemical reactions, high temperatures, pressures, etc.) taking place in them and the inability to carry out prompt repair of the equipment. Due to the increase in the operational parameters of such systems, the requirements for safe and reliable operation of equipment protecting against overpressure, i.e. to the reliability of the design of safety devices, are also increased, as they are affected by such negative factors as: increased temperatures, vibrations, aggressive working environments, etc. [1].

For technical systems with high reliability requirements, pilot-operated relief valves (PORV) with high throughput and narrow pressure response are preferred as overpressure safety devices. The PORV consists of a main valve and a pilot valve (PV), which acts as a control mechanism and senses the pressure of the working medium for pressurizing or releasing the pressure in the PORV chamber.

However, PORV designs are less reliable compared to spring safety valves, due to more assemblies and elements. During operation, PVs made in the form of spring valve devices are affected by such negative factors as wear, mechanical stresses, increased and reduced operating medium temperatures, etc. Due to all these factors, safety valve actuation reliability is reduced, which leads to faults, and then to partial and complete failures of safety system [2-3]. Sometimes PV is made in the form of a valve with electromagnetic control, but such a device has significant disadvantages: need for constant power

supply, frequent maintenance and reduction of reliability at high operating temperatures [4]. Therefore, in most cases, the pilot valve is operated without electromagnets.

Thus, the development of a PORV design with increased reliability is a priority in areas with high safety and safety requirements of safety devices.

2. Ways to improve the reliability of the pilot-operated related valves design

The standard PORV design is shown in figure 1.

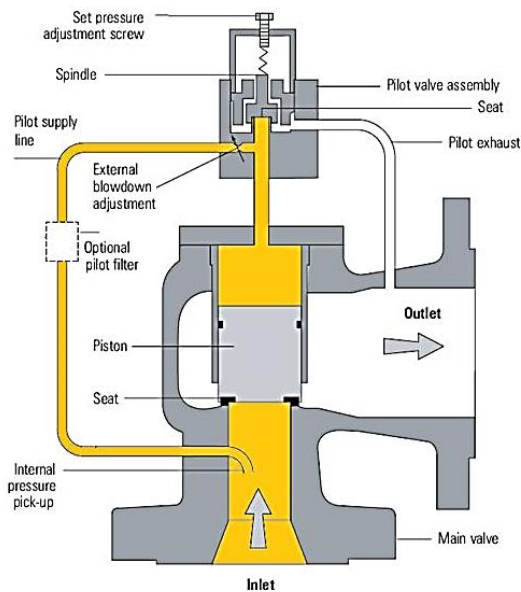

Figure 1. Standard pilot-operated relief valve design.

PORV is shown in figure 1 and is made in the form of a spring valve. During operation, its elements are affected by such negative factors as wear, mechanical stresses, corrosion, reduced and elevated temperatures, as well as their sharp difference. External vibration has a great influence on PV operability, which in certain situations can lead to self-excited valve self-oscillations [5].

In the analysis of the main failures of PV, it was found that the combination of constant stresses and high temperatures are the reasons for irreversible change in the operational properties of the spring PV. A significant effect of the sensor on the valve health is that of the failure modes, "premature opening" and "inoperability" of about 30% of these areas is caused by irreversible change of spring properties [6].

Increasing the reliability of PORV can be achieved by using more modern wear-resistant structural materials, methods of surface treatment of parts, but this gives a slight increase in reliability against the background of increased cost of construction and does not contribute to reducing the negative impact of vibration on PORV.

Increased reliability can be realized by reserving the valve with a different type system. Using different types of systems and components that are different in operation but perform the same functions in backup is a better solution, because the reasons that affect the failure of one element due to their divergence will not affect the standby element or have a weak impact [7].

In our opinion, the optimal design option is a system in which in case of failure of the main element - springs - the reserve element - metal bellows, initially unloaded, is automatically activated, at the same time these sensitive elements are of different types.

3. Pilot-operated relative valve design with adaptive regulator

Based on the above assumptions, a PORV design with a standby main valve control element, an adaptive

regulator, has been developed (figure 2) [8].

The proposed design differs from standard by availability of adaptive regulator, which is a housing with metal bellows 17 located inside it. Attached to the lower bellows cover 18 is a three-position spool distributor 20 which is located at the intersection of the impulse tubes and serves to redistribute the pressure in the PORV system.

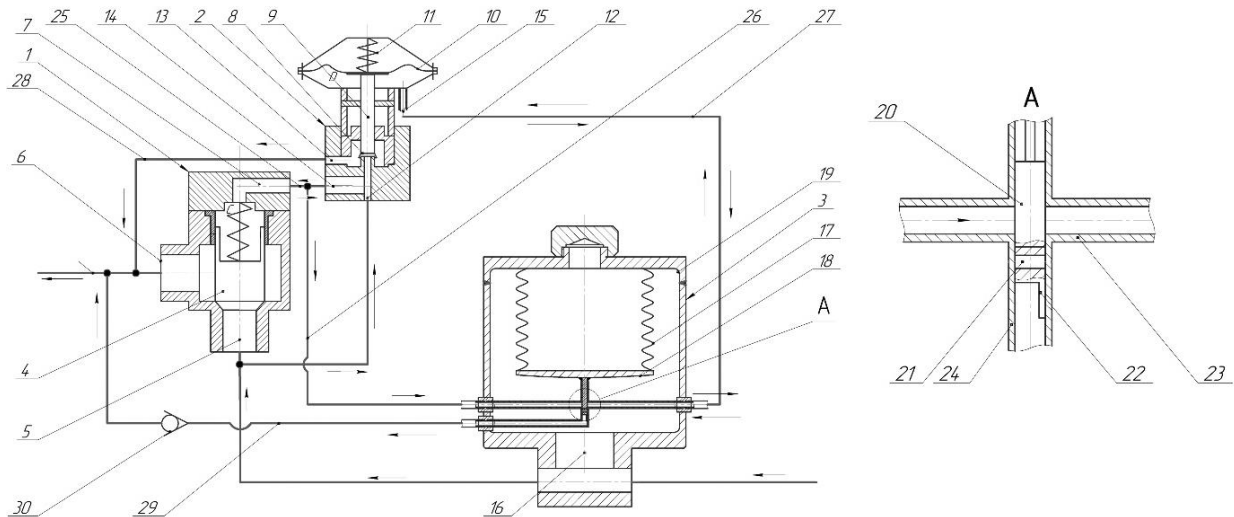

Figure 2. Scheme of work of pilot-operated relief valve with adaptive regulator: 1 – main valve; 2 – pulse valve; 3 – adaptive regulator; 4 – piston; 5 – entrance branch pipe; 6 – output branch pipe; 7 – dumping branch pipe; 8 – plate; 9 – rod; 10 – metal membrane; 11 – spring; 12 – entrance branch pipe; 13 – dumping branch pipe; 14 – branch pipe of giving (dumping); 15 – branch pipe of giving (dumping); 16 – entrance branch pipe; 17 – metal bellows valve; 18 – mobile cover; 19 – motionless cover; 20 – spool-type distributor; 21 – middle part of the distributor; 22 – lower part of the distributor; 23, 24, 25, 26, 27, 28, 29 – pulse tubes; 30 – non-return valve.

Adaptive regulator serves to create additional force to open the PV, in case of its failure at setting pressure, or to release pressure from above-piston chamber of main valve 1 in case of total failure of PV.

As the pressure rise increases above the set level, the metal bellows 17 is compressed and opens the passage in the slide valve from line 26 at the intersection of lines 23 and 24 to line 27 and the membrane chamber. The incoming medium exerts pressure on the membrane, creating an additional force to open the PV. In the event of failure of the PV and further pressure increase in the PORV system, the metal bellows continues to contract and moves the spool distributor 20 to a position where the medium from the above-piston chamber of the main valve through line 26 enters line 29 and further onto the discharge line. The main valve then opens without PV involvement.

A distinctive feature of this PORV is that the adaptive regulator, in addition to the standby control element, also performs the role of a bellows hydraulic accumulator, which is usually filled with gas, thus reducing the effects of external dynamic effects on PORV and PV, in particular by preventing PV self-tests.

4. Probability of failure-free operation of PORV system with adaptive regulator

In order to assess the reliability of the developed PORV design, it is necessary to calculate the probability of failure-free operation of the standard and proposed PORV design.

First we make a calculation for the system of standard design PORV, consisting of two valves – main and pulse. The main valve may be a subsystem consisting of a housing, a piston, a seat and a return spring, pulse valve – in the form of subsystem consisting of plate, rod, housing, seat and spring. These

two subsystems operate sequentially, without the use of redundancy. The PORV is operable if both subsystems are operable. The probability of failure-free operation of the P_{PORV} of the standard PORV design in such a case will be determined by the formula

$$P_{PORV}(t) = P_{MV}(t)P_{PV}(t) \quad (1)$$

where: P_{MV} and P_{PV} – are probabilities of failure-free operation of main and pulse valves, respectively, which are determined by formula

$$P(t) = \prod_i^n P_i(t) = \prod_i^n \exp\left(-\int_0^t \lambda_i(t) dt\right) \quad (2)$$

where: n – is the number of objects in the system; λ_i – is the failure rate of the system element i .

We present the adaptive regulator in the form of a system of three elements: bellows, slide valve and housing. The developed PORV design is in working condition in case of either PV or adaptive regulator operation.

Probability of P'_{PORV} failure-free operation of proposed PORV design is determined by formula

$$P'_{PORV}(t) = P_{MV}(t) \left[1 - \frac{1}{2}(1 - P_{PV})(1 - P_{AR})\right] \quad (3)$$

where: P_{AR} – is the probability of failure-free operation of adaptive regulator, determined by formula 2.

By reference data [9] and formulas 1, 2 and 3 we determine probabilities of failure-free operation of elements and subsystems of standard and developed design of PORV. The calculation results are shown in table 1.

Table 1. Probability of failure-free operation of PORV elements and subsystems.

Elements and nodes	λ_i^a	m^b	β_2^c	α'_i^d	t'^e	A^f	β_I^g	t''^h	$P_p(t)^i$
1 Main valve									0.951
1.1 Case	2.0	1	1	2.0	0.30	0	1.0	0.70	0.998
1.2 Piston	2.5	1	2	5.0	0.30	0	1.8	0.70	0.991
1.3 Seat	2.4	1	2	4.8	0.30	0	2.0	0.70	0.988
1.4 Returnable spring	2.8	1	5		0.30	0	2.0	0.70	0.973
2 Pulse valve									0.938
2.1 Plate	2.6	1	2	5.2	0.35	0	1.5	0.65	0.977
2.2 Rod	2.3	1	2	4.6	0.35	0	1.5	0.65	0.993
2.3 Case	2.0	1	1	2.0	0.35	0	1.0	0.65	0.9996
2.4 Seat	2.4	1	2	4.8	0.35	0	2.0	0.65	0.991
2.5 Spring	2.8	1	5	14.0	0.35	0	2.0	0.65	0.976
	Σ Standard design								0.892
3 Adaptive regulator									0.986
3.1 Bellow valve	2.3	1	1	2.3	0.20	-1.5	0.80		0.996
3.2 Valve core	2.35	1	2	4.7	0.20	0	0.80		0.990
3.3 Case	2.0	1	1	2	0.20	0	0.80		0.9999
	Σ The developed design								0.950

^a $\lambda_i \cdot 10^{-6}$, 1/h – average component failure rate during operation period.

^b m – number of i -type elements in the element group.

^c β_2 – correction factor taking into account increased failure rate of loaded components.

^d $\alpha'_i = \alpha_{ij} \cdot m \cdot \beta_2 \cdot 10^{-6}$, 1/h – failure rate of the element under load.

^e t' , h/h – time of element occurrence under load (relative).

^f A – correction factor taking into account reduction of failure rate for unloaded element.

^g $\beta_I \cdot 10^{-6}$, 1/h – failure rate of the non-loaded element.

- ^h t'' , h/h – relative time of element in unloaded state.
ⁱ $P_p(t)$ – estimated probability of failure-free operation.

As shown in table 1, the reliability of the PORV design increased from 0.892 to 0.950, which is ~ 8% of the original probability of failure-free operation of the standard design. This is because most of the time the bellows is in an unloaded state and does not perform full compression/stretching cycles, i.e. does not waste its life. These values do not take into account the reduction of vibration influence during the adaptive regulator installation, as it is difficult to determine by analytical methods the reliability indicators of technical systems under the influence of external dynamic oscillations [10].

5. Discussion

The installation of the standard design of the adaptive regulator increases the cost of the PORV, so that in order to reduce the cost of the bellows, its multilayer corrugated shell, intended for corrosion-active and high-temperature environments, can be made of several grades of steels. For a layer in contact with the working medium, corrosion resistant and heat resistant material is the optimal choice, and for other layers, conventional steel.

It is also possible to fill the metal bellows cavity with resiliently damping elements to create additional axial resistance or to adjust stiffness without replacing the sensitive element itself.

6. Conclusion

During analysis of sources due to faults and failure causes of spring valves of safety systems, significant influence of sensitive elements on total failure of the device and partial failure of operation due to influence of high stresses and temperatures leading to change of properties of structural materials, as well as state of inoperability due to influence of external vibrations has been revealed.

Given is a method of increasing reliability of a PORV by means of redundancy by a system with a different type of sensitive element, wherein an optimal scheme of the redundant system is determined.

Design of PORV with adaptive regulator is proposed and considered. The principle of operation of this device is described, advantages and disadvantages of the design are analyzed.

Reliability indices of standard and proposed PORV design are calculated. The advantages of the redundant system and increased effect of redundancy during operation under conditions of external dynamic impacts are identified. PORV redundancy by an adaptive controller system increases the reliability of the entire system by 8%, providing the specified reliability parameters while increasing the repair period and reducing the associated costs.

References

- [1] Staunton R H and Cox D F 1995 Aging and Service Wear of Spring-Loaded Pressure Relief Valves Used in Safety-Related Systems at Nuclear Power Plants *Nuclear Regulatory Commission*
- [2] Gross R and Harris S P 2006 *Proc. of ASME PVP 2006/ICPVT-11 Conference* 211-9
- [3] Bukowski J V, Gross R E and Goble W M 2013 *J. Pressure Vessel Technol.* **135**(6) 1-7
- [4] Bacanskas V P, Roberts G C and Toman G J 1987 Aging and Service Wear of Solenoid-Operated Valves Used in Safety Systems of Nuclear Power Plants: Volume 1, Operating Experience and Failure Identification *Franklin Research Center*
- [5] Makaryants G M 2017 *J. Loss Prev. Proc. Ind.* **48** 1-13
- [6] Terasmes K S et al 2019 *J. Phys.: Conf. Ser.* **1353** 012055
- [7] Dixon D F and Abbas M 1978 Prototype Bellows Sealed Nuclear Valve Development: Reliability Through Testing *Atomic Energy of Canada Ltd.*
- [8] Bashmur K A, Petrovsky E A and Terasmes K S 2019 Pat. RU 2687198 (Moscow: Rospatent)
- [9] ST TsKBA 008-2014 2014 *Pipe Fittings. Calculation and Evaluation of Reliability and Safety at the Design Stage* (Saint Petersburg: Central Design Bureau of Valve Engineering) p 84
- [10] Skousen P L 2004 *Valve Handbook* (New York: McGraw-Hill) p 447