

PAPER • OPEN ACCESS

Automated measuring system for studies of microwave filters in a wide frequency range

To cite this article: A B Gladyshev *et al* 2019 *J. Phys.: Conf. Ser.* **1333** 022003

View the [article online](#) for updates and enhancements.



IOP | ebooks™

Bringing you innovative digital publishing with leading voices to create your essential collection of books in STEM research.

Start exploring the collection - download the first chapter of every title for free.

Automated measuring system for studies of microwave filters in a wide frequency range

A B Gladyshev^{1,2}, D D Dmitriev¹, V N Tyapkin¹ and V N Ratuschnyak¹

¹Siberian Federal University, Krasnoyarsk, Russia

²E-mail: a-ghonass@yandex.ru

Abstract. The structure of an automated measuring system for the study of the frequency characteristics of microwave filters in a wide frequency range is given. It is based on a handheld probe station, a vector network analyzer, a vector signal analyzer and a signal generator. It provides automation of research and determination of the main parameters of microwave filters – amplitude-frequency characteristics, phase-frequency response, group delay differences, level signal attenuation in stop band. The function of documenting the results of measuring the parameters of microwave filters allows not only in real time, but also in post-processing to analyze and compare the characteristics of microwave filters in the frequency range from 10 MHz to 24 GHz.

1. Introduction

In order to miniaturize radioelectronic systems, developers often use microwave filters with low electrical characteristics. This is due to the fact that in the development of electronic equipment, requirements for miniaturization sometimes prevail over system quality requirements. However, improving the electrical characteristics of microwave filters can reduce their total number in the equipment.

The most important characteristic of a band-pass microwave filter is its amplitude-frequency characteristic, that is, the dependence of transmission and reflection coefficients on frequency. The central frequency of the microwave filter's passband is determined by the operating frequencies of the system being developed as a whole. In addition, there are other characteristics of the microwave filter, which also have an impact on the characteristics of the developed system:

- first pass band width of microwave filter determines the width of the working band of the electronic system or subsystem;
- standing wave ratio determines the amplitude of the signal reflected from the input of the microwave filter;
- selectivity near bandwidth determines the noise immunity of the system;
- group delay time determines the frequency dependence of the delay of the microwave filter signals;
- the width and depth of the barrier line determine the resistance of the developed electronic system to out-of-band interference.

The quality of the microwave filter is mainly determined by its frequency-selective properties.

These properties are characterized by:

- coefficients of steepness of slopes of the amplitude-frequency characteristic;



Content from this work may be used under the terms of the [Creative Commons Attribution 3.0 licence](https://creativecommons.org/licenses/by/3.0/). Any further distribution of this work must maintain attribution to the author(s) and the title of the work, journal citation and DOI.

- the level of signal attenuation in the stop bands;
- maximum bandwidth loss;
- maximum unevenness of group delay;
- return loss rate.

In solving modern problems of radio engineering, it is often necessary to ensure simultaneous fulfillment of stringent requirements for amplitude-frequency characteristics and microwave filter sizes. The combination of these qualities is an extremely difficult problem.

The constituent functional elements of the band-pass microwave filters are electrodynamic resonators [1, 2]. They interact with each other through electric and magnetic fields and have ohmic contact with other elements of the microwave filter. It should be noted that the newest designs of microstrip microwave filters have been developed with a high degree of miniaturization of resonators on various structures of strip conductors. They are very promising for creating multi-link band-pass microwave filters with good frequency-selective properties.

First of all, it is a fairly wide high-frequency boom band with a high level of microwave power suppression in it. When creating such microwave filters, it is required to accurately measure and control their parameters. And one measuring device in this case is not enough. There is no ready-made solution on the market suitable for a comprehensive study of the characteristics of microwave filters. Therefore, there is a need to create an integrated measuring system for experimental studies of microwave filters.

2. Development of an automated measuring system for studying the frequency characteristics of microwave filters

In order to study the frequency-selective properties of microwave filters, an automated measuring system was developed with a set of necessary instrumentation technology. Its structural diagram is presented in Figure 1.

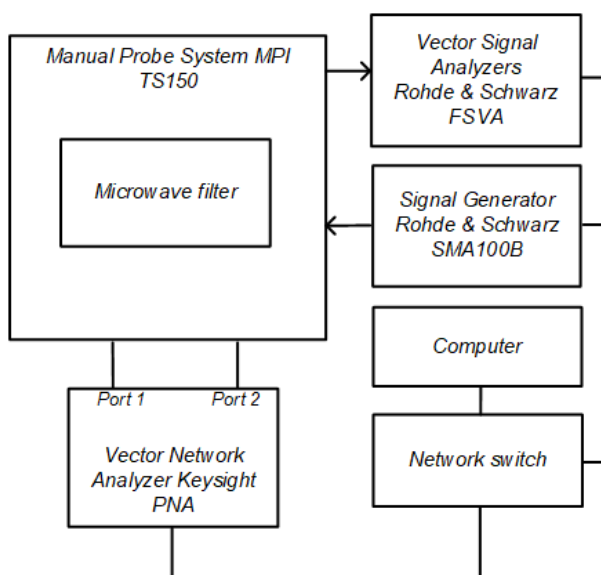

Figure 1. Structural diagram of an automated measuring system

An automated measuring system provides measurement of the following characteristics of microwave filters:

- amplitude-frequency;
- phase-frequency;
- group delay time difference;
- level of signal attenuation in the stop band within the realized dynamic range.

An automated measuring system has the following technical characteristics:

- operating frequency range from 10 MHz to 24 GHz;
- dynamic range is not worse than minus 120 dB;
- output power not less than minus 10 dBm;
- the minimum noise level is not worse than minus 114 dBm.

In modern measuring devices, various methods are used to measure the frequency characteristics of microwave filters. Currently, vector network analyzers are used for such studies. In low-cost models of network analyzers, the method using a sweep-frequency generator is used; in models for professional use, sets of harmonic signals or wideband signals are used [3].

The vector network analyzer is designed to measure the parameters of the scattering matrix of the devices under study - transmission coefficient and signal reflection coefficient. It is the main measuring device in the manufacture and testing of band-pass microwave filters. With its help, the amplitude-frequency, phase-frequency characteristics of microwave filters and the irregularity of the group delay are measured.

The constituent functional elements of the band-pass microwave filters are microwave resonators. They are electromagnetically connected both with each other and with both ports of the filter (input and output). The amplitude-frequency characteristic of the microwave filter in the region of the passband depends only on the resonant frequencies and resonator coupling. Observed on the amplitude-frequency characteristic in a wide frequency band, the maxima of the passage of microwave power in a system of coupled resonators can occur only near the resonant frequencies. Microwave resonators, in contrast to oscillatory circuits on concentrated inductive and capacitive elements, have not one, but an infinite sequence of resonant frequencies. Therefore, the band-pass microwave filters, along with the working (lowest) bandwidth, always have spurious (highest) bandwidths. While working on increasing the frequency-selective characteristics of microwave filters, first of all, they pay attention to the increase in the width and depth of the obstacle band separating the working bandwidth from the parasitic band. To study the above parameters it is not enough to use only the vector network analyzer. This is due to the fact that the measurements will be limited to the dynamic range of the measuring device, especially when measuring parameters in the obstacle bands. Therefore, it is necessary to use a microwave signal generator with a large dynamic range, giving signals to the input of the microwave filter under study within the obstacle bands and analyzing the output response.

The vector signal analyzer together with the microwave signal generator allow measuring the parameters of the obstacle bands of the microwave filters and passing the signals through them at the frequencies of the obstacle band. The combined use of an analyzer and a microwave signal generator makes it possible to measure the parameters of harmonics that occur when high-intensity signals pass through a microwave filter in the case of using semiconductor materials as a substrate.

The manual probe station is designed to connect external devices to the developed miniature band-pass microwave filters made without coaxial junctions. For automated measurement of parameters without physically reconnecting instruments to the filter under investigation, a four-port probe station is used.

For centralized remote control of all measuring instruments, special software was developed. This software operates on the National Instruments LabVIEW platform [4]. The main functions of the software include the automation of research and determination of the main parameters of microwave filters:

- amplitude-frequency characteristics;
- phase-frequency response;
- group delay difference;
- the level of signal attenuation in the stop band.

With the help of the software, the results of measuring the parameters of the microwave filters are recorded and the data is saved on the hard disk of the control PC. The developed software uses methods of remote control of measuring instruments using the tools of the software architecture National

Instruments VISA (Virtual Instrument Software Architecture). The software uses these tools for unified testing, debugging and remote control of the equipment of an automated measuring system using the LAN interface. The software implements the interface of interaction with the instrumentation of the automated measuring system in the “Request – Answer” format. The control personal computer sends a command request (measurement of the amplitude-frequency characteristic values, phase frequency characteristic, group delay time, transfer to spectral or time analysis mode, etc.) and waiting for a response (status report or measurement results) from the measuring devices.

It is possible to update the measurement results with a certain frequency (the real-time mode is not implemented in the software). The block diagram of the software operation is shown in Figure 2. The interface is shown in Figure 3. Through the software interface, it is possible to set the initial parameters of the measuring devices, adjust and control them. The measured characteristics of microwave filters are graphically displayed in the corresponding software windows.

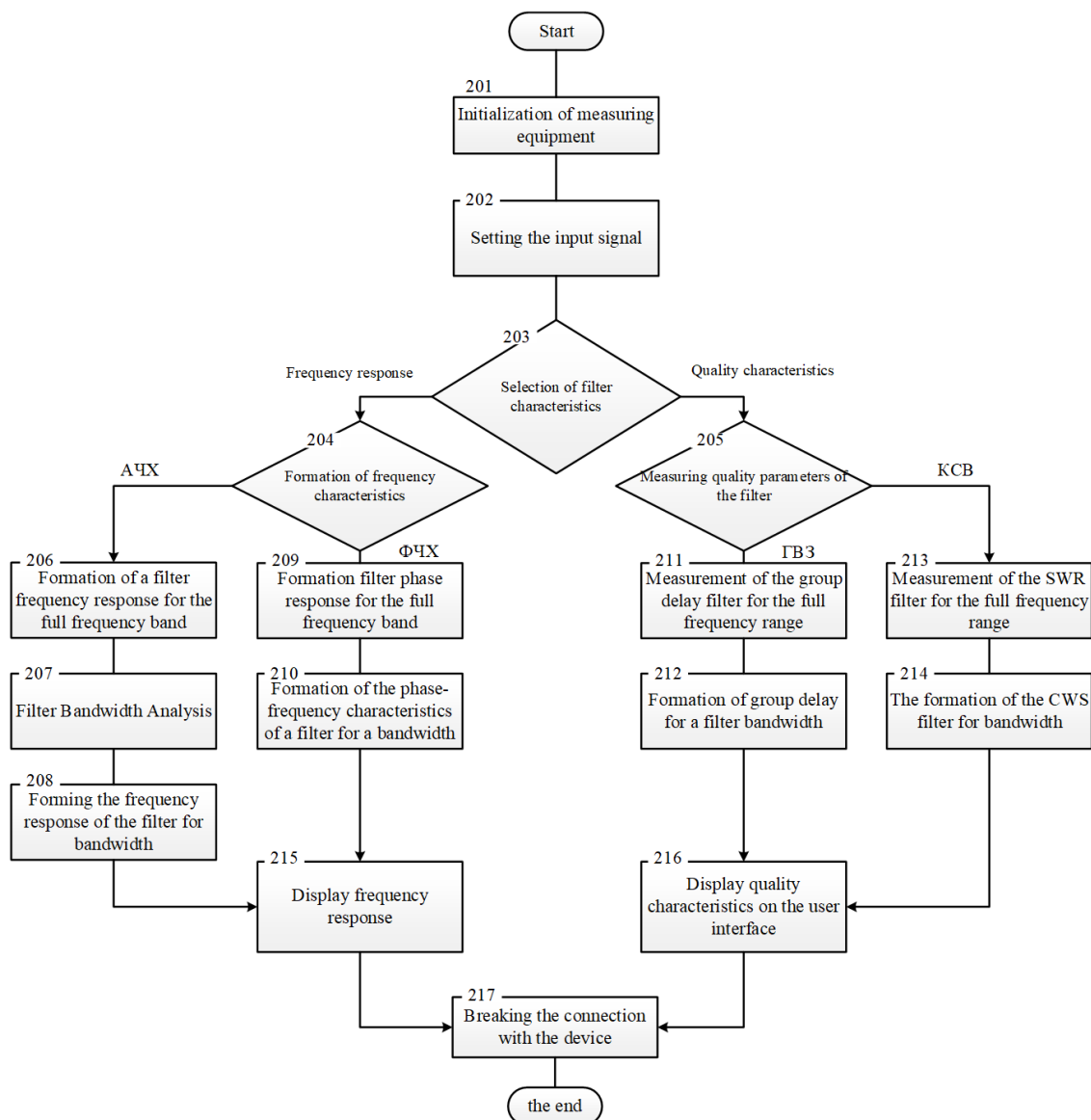

Figure 2. A block diagram of the algorithm of the software

The functionality of an automated measuring system for measuring the characteristics of a microwave filter manufactured using stripline resonators on a suspended substrate [5] is shown in Figure 4.

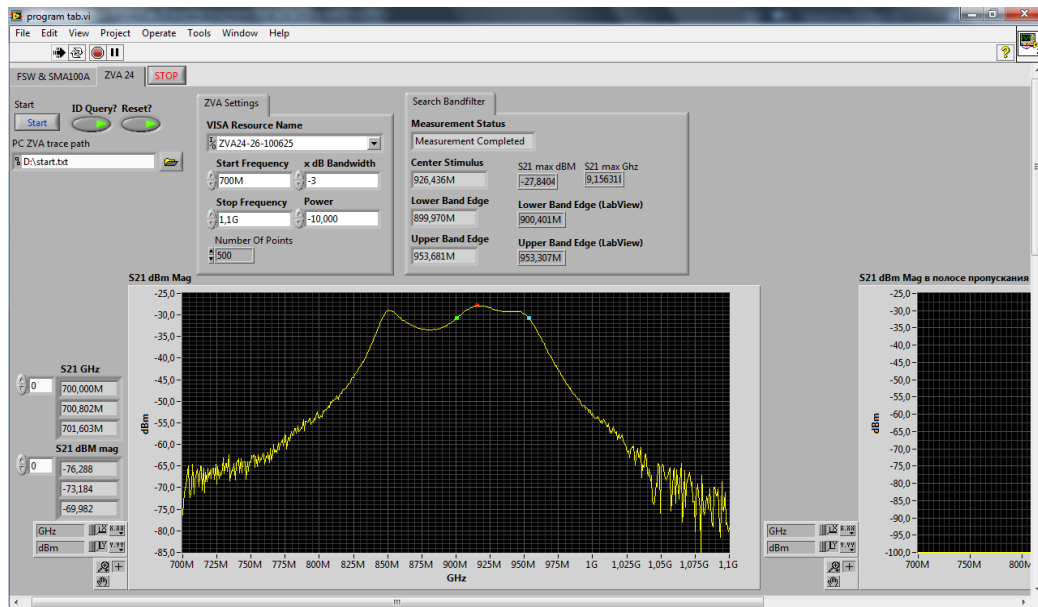

Figure 3. Software interface of an automated measuring system

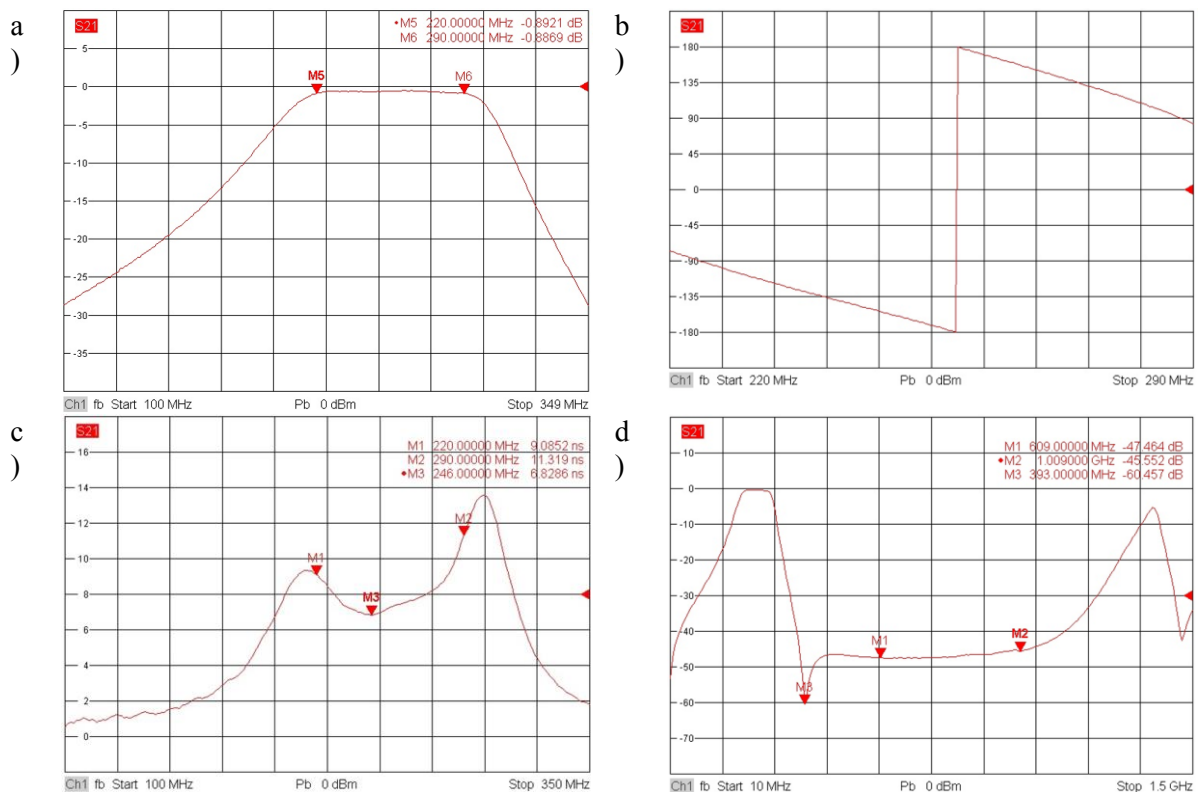

Figure 4. The results of measurements of the characteristics of microwave filters: a – amplitude-frequency characteristic; b – phase frequency characteristic; c – uniform group delay; d – level attenuation in stop band

3. Conclusion

Thus, the automated measuring system presented in the work allows not only to conduct comprehensive studies of the characteristics of microwave filters, but also to automate this process with the help of the developed software. The function of documenting the results of measuring the parameters of microwave filters allows not only in real time, but also in post-processing to analyze and compare the characteristics of microwave filters in the frequency range from 10 MHz to 24 GHz.

Acknowledgments

This work was supported by the Ministry of Education and Science of the Russian Federation in the framework of the Federal target program “Research and development of priority directions of development of the scientific-technological complex of Russia for 2014-2020” (agreement № 14.575.21.0142, unique ID project RFMEFI57517X0142).

References

- [1] Oh S, Lee H, Jung J-H and Lee G-Y 2014 A Novel Wideband Miniaturized-Element Frequency Selective Surface *Int. J. of Microwave Science and Technology* 857582
- [2] Belyaev B A and Tyurnev V V 2016 Design of bandpass filters composed of dielectric layers separated by gratings of strip conductors *Optics Letters* **41** (3) 536–539
- [3] Roblin P 2011 *Nonlinear RF Circuits and Nonlinear Vector Network Analyzers: Interactive Measurement and Design Techniques* (Cambridge; New York – Cambridge University Press)
- [4] Official site of the National Instruments Company [Online], Available: <http://www.ni.com>
- [5] Belyaev B, Khodenkov S and Dmitriev D 2018 Investigation of microstrip band-pass filters based on 2d electromagnetic crystal *Proc. 2018 Ural Symposium on Biomedical Engineering, Radioelectronics and Information Technology, USBEREIT 2018* (Yekaterinburg; 7 May 2018 до 8 May 2018) 245–248.