

PAPER • OPEN ACCESS

Impact assessment of cutting angle of blade on storage density value of ice cutting process

To cite this article: V A Ganzha *et al* 2020 *J. Phys.: Conf. Ser.* **1515** 042032

View the [article online](#) for updates and enhancements.



IOP | ebooks™

Bringing together innovative digital publishing with leading authors from the global scientific community.

Start exploring the collection—download the first chapter of every title for free.

Impact assessment of cutting angle of blade on storage density value of ice cutting process

V A Ganzha¹, A S Lunev¹, Yu F Kaizer^{1,4}, V I Vereshchagin¹, A V Ganzha² A S Satyshev¹, E N Karelin³ and Ch D Chavyraa⁴

¹ Siberian Federal University, 660041, Krasnoyarsk, 82/6, Svobodny Avenu, Russia

² Krasnoyarsk State Medical University named after Professor V.F. Voyno-Yasenetsky 660022, Krasnoyarsk, 1, Partizan Zheleznyak str., Russia

³ Siberian Fire and Rescue Academy of Firefighting Service of EMERCOM of Russia, 662972, Krasnoyarsk Territory, Zheleznogorsk, 1, Severnaya St., Russia

⁴ Tuva State University, 667000, Kyzyl, 36, Lenin str. Russia

E-mail: vladimirganzha@yandex.ru

Abstract. This paper concerns main results of research on interacting process of blade and ice during mechanical corrosion. It describes experimental research conditions and their main results. The paper shows argument of reasonable geometrical parameters of blades providing minimal storage density value of tested process.

1. Introduction

Events providing continuous development of Northern Territory and events related to exploitation of The Arctic are rush implemented in Russia. It is directed to series of strategic government documents [1].

The main aim of realization of noted events is searching new sources of strategic material such as oil and gas for stabilization of government resource base. Growth of requirement of road, building and operating organizations in high technologies such as equipment for mechanical ice destruction makes conditions for high rates of exploration and exploitation of new production fields with rough weather conditions (solid snow-ice sediments) on pavings which could be cleaned.

2. Timeliness of the item

Mechanical way of winter paving maintenance is widely used for cleaning up fresh-fallen and compressed snow. Ecological safety and efficiency are the advantages of that way in comparison to chemical one. Using mechanical way for destruction of fresh-fallen and compressed solid snow-ice sediments is limited due to functional unpracticalness of working tools of known road machinery.

Above mentioned shows timeliness of papers on development of known working tools of road machinery and creating new ones, which conform the destruction of solid materials and provide its mechanical destruction with minimal storage density of the process.

The basic point of research is using cutting blades inside of shift working tools construction to accommodate it for destruction of ice and solid snow-ice sediments on road pavements.

The idea confirms with separately directed strategy in science and technique formed by Professor V.I. Balovnev. It runs on efficiency upgrading of working tools of road machinery and adapting to



Content from this work may be used under the terms of the [Creative Commons Attribution 3.0 licence](https://creativecommons.org/licenses/by/3.0/). Any further distribution of this work must maintain attribution to the author(s) and the title of the work, journal citation and DOI.

work under different conditions. The main thing is to sectional equipage of machinery with single cutting blades placed according to the schemes. Schemes provide destruction of solid material with minimal storage density value and maximum operating rate [2].

It is well known that circular instrument is widely used in constructions of agricultural implements, heading machine and inside working tools of boring machines, diggers and bulldozers. Papers of A.S. Soyunov [3], S.N. Dozdov [4], A.Y. Nesmiyan [5], L.I. Baron, L.B. Glatman, S.L. Zagorskij, E.K. Gubenkov [6-9], A.A. Khoreshok, L.E. Mametev, A.Y. Borisov [10], R.B. Zhelukevich [11] and others show key findings of interacting process of circular instrument and grounds, rocks and frozen grounds.

3. Terms of reference

Interacting processes of circular cutting instrument and solid snow-ice sediments and ice are understudied. It inhibits performing accounting during creating new constructions of working tools of road machinery and developing current ones. That is needful to improve efficiency of road mashinery. Assertedv demonstrates relevance of experimental research.

Finding out dependences between change of energy parameters of developed equipment and cutting angle of blade, cutting speed, external temperature, which influences on hardnessof destructed material, corner radius of instrument's cutting edge, changed depth and width of cut is a crucial task of these researches.

The article represents main findings of first step of research on that direction. working purpose is finding out dependences between change of energy parameters of cutting blade destructing ice and cutting angle of blade. Also the goal is to determine efficient geometric parameters of such instrument to minimize the cost per unit of energy.

4. Experimental procedure

Single-sided Sharpen disk cutter with continual wedge rim of frusto-conical shape is taken as a cutting instrument (figure 1).

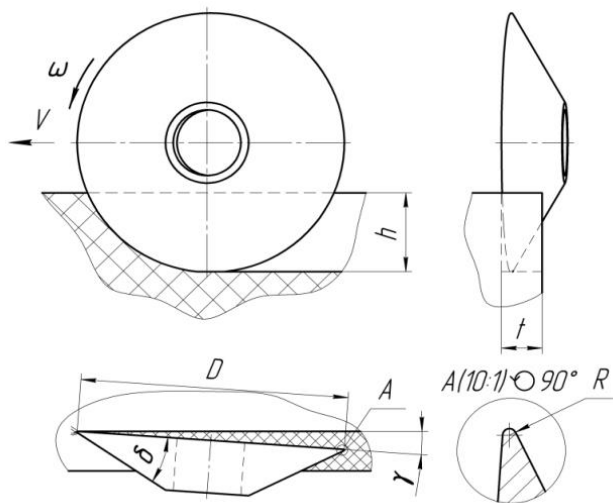

Figure 1. Operating procedure of cutting disk: h – depth of cut; t – pitch of cut; γ – impinging angle; δ – cutting angle; D – disk diameter; R – corner radius of instrument's cutting edge.

Such form of instrument permits its spacing under different angles toward the surface of developed material.

Impinging angle is equal to $\gamma = 5^\circ$ to reduce frictional area between bigger cone base and material.

Disk diameter $D = 0,2 \text{ m}$. Crockness of construction and requirement of installing plate piers holding disk cutters on final element eliminates because of such diameter. Moreover, it ensures needed depth of cut.

Disks with cutting angle $\delta = 15^\circ$; $\delta = 30^\circ$; $\delta = 45^\circ$; $\delta = 60^\circ$ are used.

Instrument material – steel 40HN GOST 4543-71 [12]. Hardness of material measured by hardness gauge UZIT – 3 is *HRC* 53 at the average [13].

Depth of cut is $h = 60 \text{ mm}$. That value matches with allowable thickness of cuttings which are cut by dump working tools with automatic control system.

Pitch of cut t (thickness of cuttings), is: 10, 20, 30 and 40 *mm*. Criterion $t \leq h$ was kept. In this case ice destruction is realized using half-blocked scheme which needs less energy consumption. But if $t > h$ it should be more energy-intensive blocked scheme of cutting.

Test is done under external temperature from 2 to 6 °C below zero when ice formation on roof pavings is the most probable.

Cutting speed is 0,51 *m/sec*. As a part of that step of the research this condition is admitted to be enough. It is known that cutting velocity variation from 0,05 to 1 *m/sec* doesn't have a meaningful effect on resistance force value of destructed material to cutting by circular tangential instrument [9, 15].

Destructed material is blocks made of natural freshwater ice. Texture of blanket of blocks is congruent to solid snow-ice sediments on road pavements. Approximate proportions of ice blocks are: 260x300x510 *mm*. Material density $\rho_C = 0,75 \text{ g/sm}^3$. Compression strength $\sigma_c = 1,8 \div 2,3 \text{ MPa}$.

Experimental research on ice destruction by cutting disk are done on laboratory bench, made according to paper [14].

Instrument converter of bench is tensometric element including steel quadrilateral bearing plate. tensometric cylindrical beam executed as coreless glass with thick bottom and four thread holes in is rigidly fixed on the downside of that plate upright. There are blocks of tensometric resistance transducers to measure horizontal P_T , side P_B and vertical P_B forces of cutting resistance on the surface of tensometric beam. Bolts attach hanger having cutting disk on the axis to the thick bottom of tensometric beam. Laboratory bench construction provides attachment of tensometric element to the instrument on two parallel cylindrical axis and its moving along those axis from far right to far left point while turning on the electric drive.

Data measurement system including PC, analog data digitizer L-154, software *Power Graph*, tensometric intensifier UT1-10 ensures signs recording, got from measurement blocks, keeping findings and capability of its later processing. Maximum relative measurement error is less than 2 %.

Ice block is attached on the supporting plate of bench for testing. Laboratory bench construction furnishes moving of bearing plate with the ice block attached on it in horizontal surface at a given distance perpendicularly to the main axis of bench. Thereby, Pitch of cut change t is provided (thickness of cuttings) i.e. distance between the side plate of example closest to the instrument to the cutting line, which is defined by path of motion of cutting point of this instrument (figure 1).

Cutting depth-setting h is carried out through the use of equithickness steel plates in sufficient quantity which are installed on the bearing plate under the lower edge of ice block.

Turning on the electric drive tensometric element with cutting disk attached on moves from far right to far left point along the main axis of bench destructing the material. Cutting by each disk is conducted by serial changing of pitch of cut t in the whole the range under study.

5. The results of experimental studies

Dependency diagrams of each cut resistance force (P_G, P_V, P_B), cutting angle δ and pitch of cut t [16] are based on statistic process results of all tests, provided by the program of experiment. The math of storage density of ice cutting by circular disks with different values of cutting angle and pitch of cut is performed according to equation (1). Dependency diagrams of storage density E of cutting and cutting angle δ (figure 2).

$$E = 0.000272 \frac{P_G}{S_{CP}}, kW \cdot h / m^3, \quad (1)$$

where P_G – horizontal force of cutting, *kN*; S_{CP} – shear area, described by following expression.

$$S_{CP} = h \cdot t, m^2, \quad (2)$$

where h – depth of cut, m ; t – pitch of cut, m .

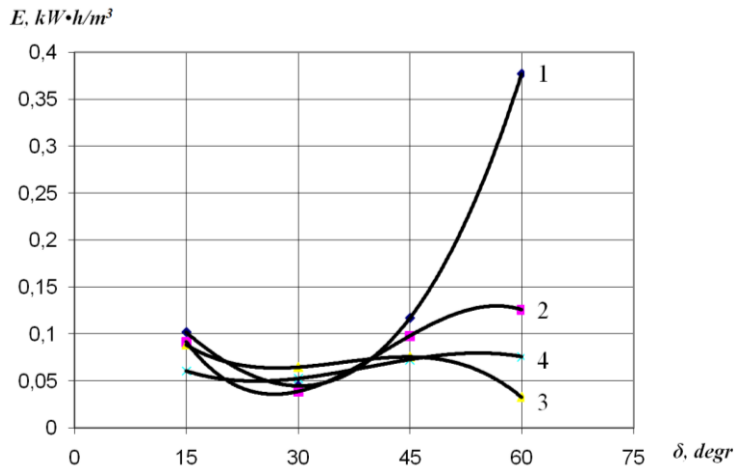

Figure 2. Dependency diagrams of storage density and cutting angle of disk: 1 – when $t = 10$ mm; 2 – when $t = 20$ mm; 3 – when $t = 30$ mm; 4 – when $t = 40$ mm.

Dependency diagrams review shows that minimal storage density of the process is provided by cutting the ice with disk having cutting angle $\delta = 30^\circ$ across the entire range of pitch of cut t (10, 20, 30 and 40 mm). Previously the minimal values of horizontal cutting resistance force P_T were obtained under same conditions (1).

Thus, results of experimental research provide rationalization for geometric parameters of cutting disk: diameter $D = 200$ mm and cutting angle of distributing edge $\delta = 30^\circ$.

Interacting process of instrument having indicated parameters, with solid snow-ice during mechanical destruction, flows under small values of cutting resistance forces and small storage density of the process.

Paper [17] shows construction of dump working body for removing snow-ice slope on road pavements. Working body is fitted with cutting disks.

Configuration plan of cutting disks group on the working body arranges cross-strapping of housing area of contiguous disks. The comparative math of resistance force W_I , (kN) of solid snow-ice sediments to cutting by main standard grader's dump GS-25 [18] and of resistance force W_I^1 , (kN) of the same substance to the cutting by dump with cutting disks under the same width of cut B , m .

In accordance with the obtained results math of storage density E_I^1 , ($\kappa W \cdot h / m^3$) of the process and comparison of findings to the value of this parameter E_I , which is provided by standard grader's dump GS-25, is performed.

Accounting results tell about significant (in 2, 3 times) decrease of storage density values of the process of destruction the snow-ice sediments by working tool of suggested construction in comparison to the same storage density of the process provided by standard grader's dump GS-25.

6. Conclusion

Results above confirm the capacity of high-impact destruction of the ice and solid snow-ice sediments on the road pavements by working tools with cutting disks having minimal storage density value and the same efficiency of equipment.

Fitting out working tools of road machinery by cutting disks having reasonable parameters gives a wider field of use of mechanical cleaning, higher efficiency of destruction the ice and snow-ice sediments on the pavements. Also, it minimizes purchase costs for expensive specialty vehicles and cuts expenses on chemically reactive deicing agents.

References

- [1] Development strategy of polar zone of Russia and homeland security providing until 2020. Approved by President of Russia 2013.02.20 Retrived from <http://government.ru/news/432/>.
- [2] Balovnev V I 1981 *Road machinery with working elements of boost functioning* (Moscow: Engineering)
- [3] Soyunov A S 2011 *Parametres validation of disk tillage tools* (Omsk: Omsk State Agrarian University n. a. P A Stolypin)
- [4] Drozdov S N 2013 *Structural operating parameters validation of vibration generator of tillage tools* (Orenburg: Orenburg State Agrarian University)
- [5] Nesmiyan A Y 2014 Comparative characteristics of tillage tools *Tractors and agricultural machinery* **3** 23–5
- [6] Baron L I 1966 *Rock destruction physically* (Moscow: Science)
- [7] Baron L I, Glatman L B and Gubenkov E K 1968 *Rock destruction by continuous heading machine* (Moscow: Science)
- [8] Baron L I, Glatman L B and Zagorskij S L 1969 *Rock destruction by continuous heading machine. Destruction by rollers* (Moscow: Science)
- [9] Baron L I 1973 *Rock destruction by continuous heading machine. Destruction by tangential tools* (Moscow: Science)
- [10] Borisov A Y 2016 *Developing two-crown arrow-shaped operating device of continuous heading machine with disks* (Kemerovo: Kuzbass State Technical University n. a. T F Gorbachev)
- [11] Zhelukevich R B 2013 *Theory and practice of creating working bodies of construction and road machines with disk cutters* (Omsk: SibADI)
- [12] GOST 4543-71 2008 *Alloy structural steel products. Technical standards* (Moscow: Rosstandart)
- [13] Hardness gauge UZIT–3 2011 *Engineering instruction* (Yekaterinburg: ZAO NPO Introtest)
- [14] Ganzha V A, Zhelukevich R B and Bezborodov Y N 2011 Laboratory bench for excavating part of an earthmoving machines *Pat. 2429459 RU, MPK G01M 13/00*
- [15] Sokolov L K 1976 *Research on cutting frozen soil to choose reasonable parameters of working tools of excavators* (Moscow: Vniistroydormash)
- [16] Ganzha V A 2018 *Snow-ice sediments destruction physically* (Krasnoyarsk: Siberian Federal University)
- [17] Zhelukevich R B, Ganzha V A and Bezborodov Y N 2010 Working tool for removing snow-ice sediments from the surface of roads and aerodromes *Pat. 2396389 RU, MPK E 01H 5/12*
- [18] GOST 11030-93 1994 *Autograders. Common technical standards* (Moscow: Rosstandart)