

PAPER • OPEN ACCESS

## Improvement of the plane-parallel movement of the attachment of the feller-bunchers machine LP-19

To cite this article: E N Bogdanov *et al* 2020 *J. Phys.: Conf. Ser.* **1515** 042059

View the [article online](#) for updates and enhancements.



**IOP | ebooks™**

Bringing together innovative digital publishing with leading authors from the global scientific community.

Start exploring the collection—download the first chapter of every title for free.

# Improvement of the plane-parallel movement of the attachment of the feller-bunchers machine LP-19

E N Bogdanov<sup>1</sup>, A V Egorov<sup>1</sup>, I A Polyanin<sup>1</sup>, A V Lysyannikov<sup>2</sup>, Yu F Kaizer<sup>2</sup>, R B Zelykevich<sup>2</sup>, A V Kuznetsov<sup>3</sup> and T Y Matkerimov<sup>4</sup>

<sup>1</sup> Volga State University of Technology, 424000, Yoshkar–Ola, 3, Lenin Square, Russia

<sup>2</sup> Siberian Federal University, 660041, Krasnoyarsk, 82/6, Svobodny Avenu, Russia

<sup>3</sup> Krasnoyarsk State Agrarian University, 660074, Krasnoyarsk, 2 Kirenskogo, Russia

<sup>4</sup> Kyrgyz State Technical University, 720044, Bishkek, 66, Mira Avenu, Kyrgyzstan

E–mail: kaiser171074@mail.ru

**Abstract.** This paper presents a mathematical model of the articulated manipulator feller-bunchers machine LP-19 (FBM LP-19) and allows you to identify the laws of motion of the boom, the stick and stand feller-bunchers head (FBH) depending on the volume of the working fluid in the hydraulic cylinders drive the boom and stick. Based on the results of mathematical modeling, a method and means for controlling the trajectory of the stick, arrow, and FBH with one complex control device that provides the movement of the FBH close to the plane-parallel one. The dependences of the position of FBH in the vertical plane of the boom and stick were established using the developed integrated device and without it. It has been experimentally established that the use of the developed integrated control device firstly reduces the time of the aiming operation of the FBH (changing the horizontal outreach) and secondly, the average production time of unit of wood is less than that of the base machine, which allowed increasing the productivity of the FBM compared to the base one.

## 1. Introduction

The analysis of the research carried out so far in the field of plane-parallel movement of feller-bunchers head of manipulator machines shows that the main research is focused on the development of new types of plane-parallel manipulators that provide the maximum speed of technological operations [1-15]. However, at the moment, a significant number of manipulator machines are used, in particular for timber cutting, which have a need to ensure plane-parallel movement of the feller-bunchers head, but this need has not been realized for various reasons [16, 17]. Feller-bunchers machine LP-19 are widely used in timber cutting operations in the Russian Federation [18]. Hydraulic systems and designs of manipulators VPM LP-19 do not provide synchronous operation of hydraulic motors of manipulators, necessary to reduce the time of technological operations. The lack of a solution to the issue of ensuring plane-parallel movement of the feller-bunchers head FBM LP-19 significantly hinders the development of automation of technological operations. Thus, this article is relevant, since its successful implementation will allow us to move to solving the problems of automation of technological operations of FBM LP-19.



## 2. Materials and methods

The goal of this article is to improve the plane-parallel movement of the feller-bunchers head the LP-19.

To achieve the goal, it is necessary to solve the following tasks:

1. Develop a mathematical model of the articulated manipulator FBM type LP-19, which allows to estimate the spatial movement of the elements of the articulated manipulator during the movement of the feller-bunchers head, close to the plane-parallel.

2. To identify the dependence of the sucked and displaced fluid in the hydraulic cylinders of the manipulator.

3. Develop a method and means for controlling the trajectory of the handle and arrow of the FBM type LP-19 with a single complex device (joystick) that improves the plane-parallel movement of the feller-bunchers head.

4. To justify the reduction in work cycle time pickup and pull felled tree FBM type PL-19 when using the control trajectory of the handle and arrows in a single integrated device, providing the movement feller-bunchers head close to parallel.

The object of the study is the mechanism of spatial movement of the FBM LP-19.

The solution of the problem of ensuring plane-parallel movement of the feller-bunchers head FBM LP-19 may require additional loading of the pumping station of the machine. Therefore, it is necessary to find ways to use the flow of working fluid between the cavities of working hydraulic cylinders when performing work operations in order to ensure the plane-parallel movement of the FBM LP-19 feller-bunchers head.

Therefore, it is necessary to find ways to use the flow of working fluid between the cavities of working hydraulic cylinders when performing work operations in order to ensure the plane-parallel movement of the feller-bunchers head VPM LP-19. To do this, it is necessary to develop a mathematical model for changing the spatial position of the articulated manipulator VPM LP-19 and determine the amount of working fluid displaced and sucked by the working hydraulic cylinders of the articulated manipulator drive.

Figure 1 shows the original design scheme with the calculated grid applied and the original axes. We transform it into an equivalent scheme (figure 2), which will allow us to perform mathematical modeling of the plane-parallel motion of the feller-bunchers head.

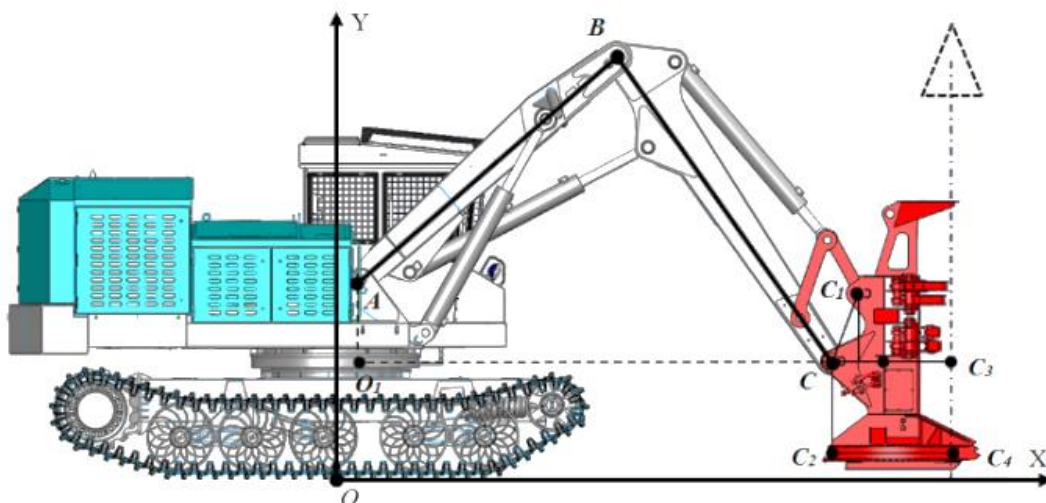

**Figure 1.** Feller-bunchers machine LP-19 initial calculation scheme.

We transform it into an equivalent circuit (figure 2), which will allow mathematical modeling of plane-parallel motion of the feller-bunchers head.

The plane parallel movement of the feller-bunchers head is characterized by a constant position of the angle of inclination of the feller-bunchers head ( $\angle \delta = \text{const}$ ,  $\triangle CC_1C_5$  и  $\square CC_2C_4C_3$ ).

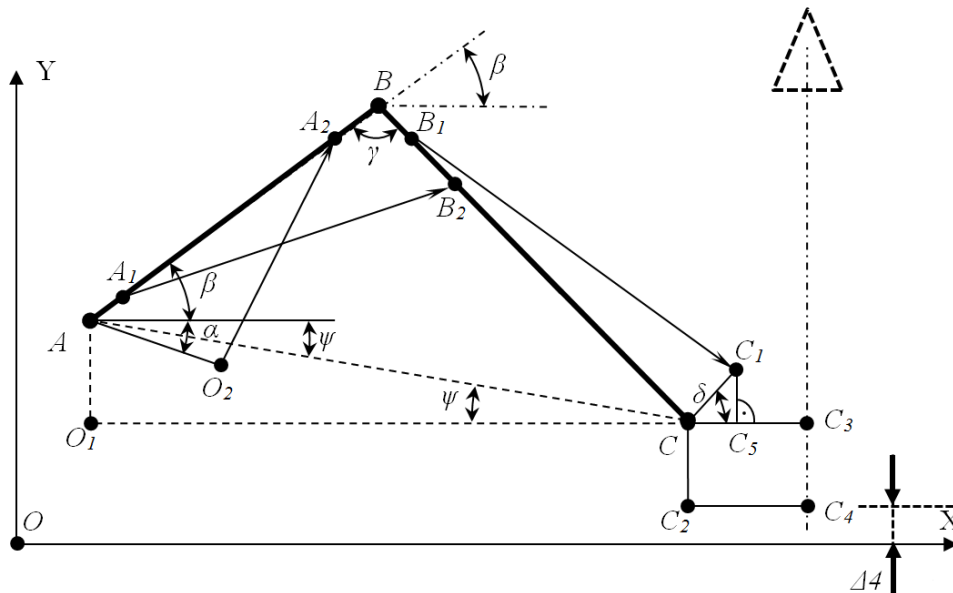

Figure 2. Equivalent calculation scheme FBM LP-19.

Thus, knowing the trajectory of the point C and its value, in the process of changing horizontal outreach feller-bunchers head from the minimum value to the maximum from the axis of rotation of the platform, it is necessary to determine the changes of the lengths of the boom cylinders ( $\Delta 1$ ), stick and feller-bunchers head ( $\Delta 3$ ) (figure 3).

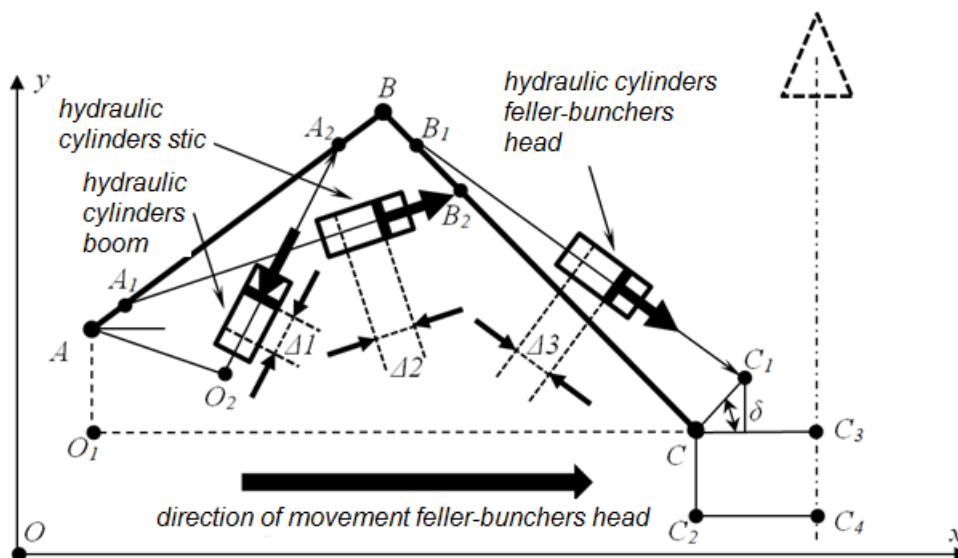

Figure 3. Scheme of work of the hydraulic cylinders when the horizontal outreach feller-bunchers head.

Those it is necessary to solve the inverse problem by the known value of the feller-bunchers head horizontal outreach and its parameters. These values are interrelated with the flow rates of the hydraulic cylinders and, which allows us to determine the amount of working fluid displaced and sucked by the working hydraulic cylinders of the articulated manipulator drive (figure 3).

In the calculation scheme (figure 2) of the plane-parallel motion of the feller-bunchers head, the known values are:

1) The length of the links:  $AB$  – boom;  $BC$  – stick;  $CC_1C_5$  и  $CC_2C_4C_3$ ; and etc. geometric parameters of the links in figure 2.

2) Height of the stump of a cut tree  $\Delta 4$ ;

3) Initial values of angles  $\beta, \gamma$ ;

4) Angle of position of the boom hydraulic cylinder  $\alpha$ .

Variables (searchable) values are:

1) Boom angles  $\beta$  and stick  $\gamma$ ;

2) The length (horizontal outreach) of the boom hydraulic cylinders ( $\Delta 1$ ), stick ( $\Delta 2$ ) и feller-bunchers head ( $\Delta 3$ ).

Let us determine the dependences of the volumes of liquids in the hydraulic cylinders on the change in the angles formed by the boom, the stick, the feller-bunchers head. From figure 3 it can be seen that when in the implementation out plane-parallel motion of the feller-bunchers head (at the time of pointing at a tree), the considered scheme works as follows. To increase the horizontal outreach of the boom, the hydraulic cylinders of its drive are retracted, so that excess fluid from the piston cavity can be used to drive other hydraulic cylinders of the manipulators. At the time of increasing horizontal outreach stick and feller-bunchers head, the hydraulic cylinders of their drives extension, the fluids of the stock cavities of which can also be used. Thus, the extension of the manipulator is accompanied by the production of excess fluid in the hydraulic cylinders of the drive. There is a possibility of their mutual use, which can be expressed as follows:

$$2 \times V_{h.b.} = V + V_{h.s.} + V_{h.h.}, \quad (1)$$

where  $V$  – equalizing fluid volume, dependent on the magnitude of the departure of the manipulator;  $V_{h.b.}$  – volume hydrocylinder boom;  $V_{h.s.}$  – volume hydrocylinder stick;  $V_{h.h.}$  – volume hydrocylinder feller-bunchers head.

$$V = V_{h.s.} + V_{h.h.} - 2 \times V_{h.b.}$$

$$|V| = S_{\Pi} \times \frac{\sqrt{4A_1B_2^2 - 16A_1B \times BB_2 \sin \frac{\gamma_1 + \gamma_2}{2} \times \sin \frac{\gamma_1 - \gamma_2}{2} - 2A_1B_2}}{2} +$$

$$S_{\Pi} \times \frac{\sqrt{4B_1C_1^2 - 16B_1C \times CC_1 \sin \frac{2\beta + 2\gamma - \delta_1 - \delta_2}{2} \times \sin \frac{\delta_2 - \delta_1}{2} - 2B_1C_1}}{2} -$$

$$2 \times S_{\Pi} \times \frac{\sqrt{4AO_2^2 - 16AO_2 \times AA_2 \sin \frac{2\alpha + \beta_1 + \beta_2}{2} \times \sin \frac{\beta_1 - \beta_2}{2} - 2A_2O_2}}{2}$$

Figure 4 presents a graph of the dependence of the stroke of the hydraulic cylinders of the boom, stick on the horizontal outreach of the feller-bunchers head from minimum to maximum values.

Figure 5 shows a graph of the change in the volume of fluid in the cavities in the hydraulic cylinders of the boom and stick from the horizontal outreach of the feller-bunchers head.

A comparative analysis showed that the volume of liquid displaced by the boom hydraulic cylinder is comparable in volume with the volumes consumed by the stick hydraulic cylinder to complete the working stroke.

Thus, the use of the volume of fluid displaced by the boom hydraulic cylinder allows avoiding additional loading of the pumping station of the machine and organizing the operation of the hydraulic system of the FBM LP-19 in such a way as to ensure the movement of the feller-bunchers head close to plane-parallel.

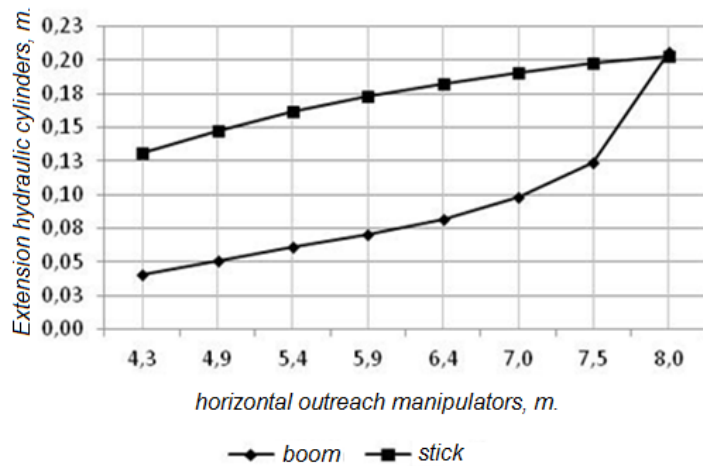

**Figure 4.** Dependence of the stroke of the boom and stick hydraulic cylinders on the horizontal outreach of the feller-bunchers head.

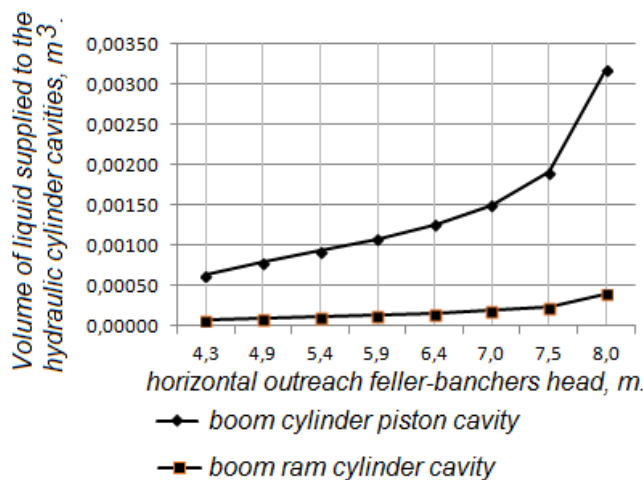

**Figure 5.** Dependence of the volume of fluid supplied to the cavity of the hydraulic cylinders of the boom and stick from the departure of the feller-bunchers head.

Figure 6 shows an additional element (P6 divertor) and its location in the FBM LP-19 hydraulic system, which allows for the movement of feller-bunchers head close to plane-parallel.

### 3. Results and discussion

In order to confirm the improvement of the plane-parallel movement of the attachment of the FBM LP-19, experimental studies were conducted on a horizontal platform in the assembly shop of the FBM LP-19 of LLC "Lestechkom".

To conduct research at the site, an experimental setup was created (figure 7), and measurements made it possible to compare the spatial position of the feller-bunchers head. Using a contrast mark in the form of a vertical measuring scale, applied at the end of the axis of attachment of the feller-bunchers head to the stick and a horizontal measuring scale, which was located on the floor surface of the shop with measuring indicators located at a distance of 500 mm (figure 8).



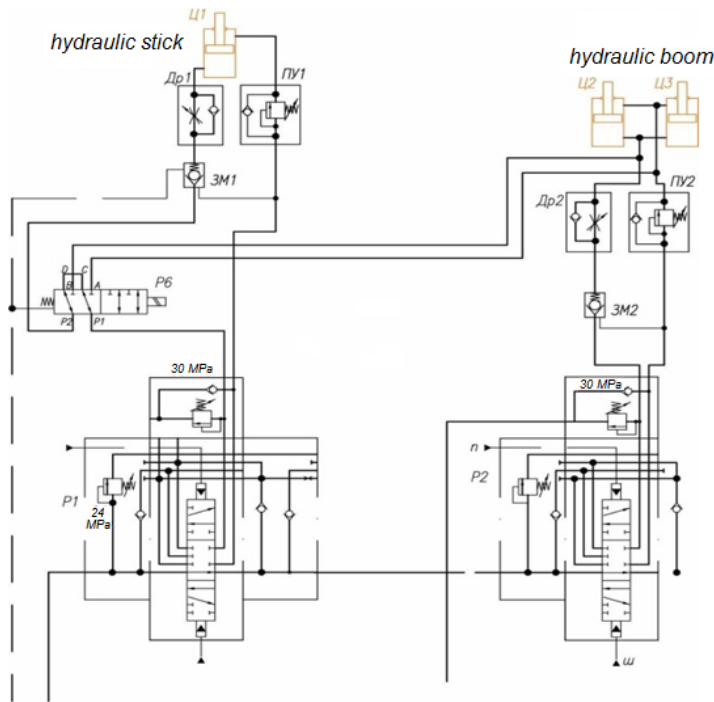

**Figure 6.** Scheme of installation of the diverter in the hydraulic system FBM LP-19.

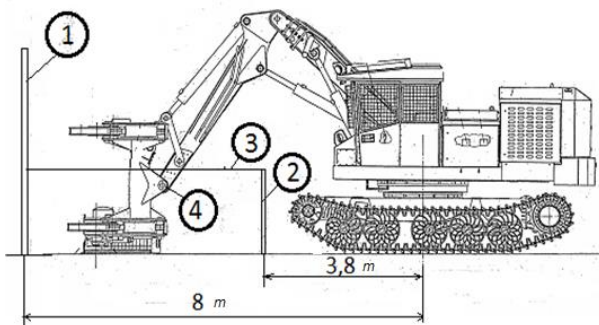

**Figure 7.** Scheme of an experimental setup for the study of plane-parallel motion of the feller-bunchers head FBM LP-19: 1 – pole (length 4 meters); 2 – stand (length 1,5 meters); 3 – laser level beam; 4 – mounting axis feller-bunchers head.



**Figure 8.** Schemes for applying a vertical and horizontal measuring scale.

The average results of measuring the dependence of the vertical position of the feller-bunchers head FBM LP-19 on the horizontal movement of the feller-bunchers head in the case of using and not using the diverter are shown in figure 9. The mark "0" corresponds to the position of the feller-bunchers head at the maximum horizontal outreach.

The equation of motion of the feller-bunchers head FBM LP-19 in the case of using a standard hydraulic circuit with a 99,2 % confidence is described by the equation:

$$y = 0,1191x^6 - 1,0447x^5 + 1,806x^4 + 9,1571x^3 - 37,028x^2 + 27,291x - 12,4$$

The equation of motion of the feller-bunchers head FBM LP-19 in the case of using a diverter in the hydraulic circuit with a 98,4 % confidence is described by the equation:

$$y = -1,1384x^6 + 14,825x^5 - 74,014x^4 + 175,64x^3 - 193,24x^2 + 71,817x + 0,0355$$

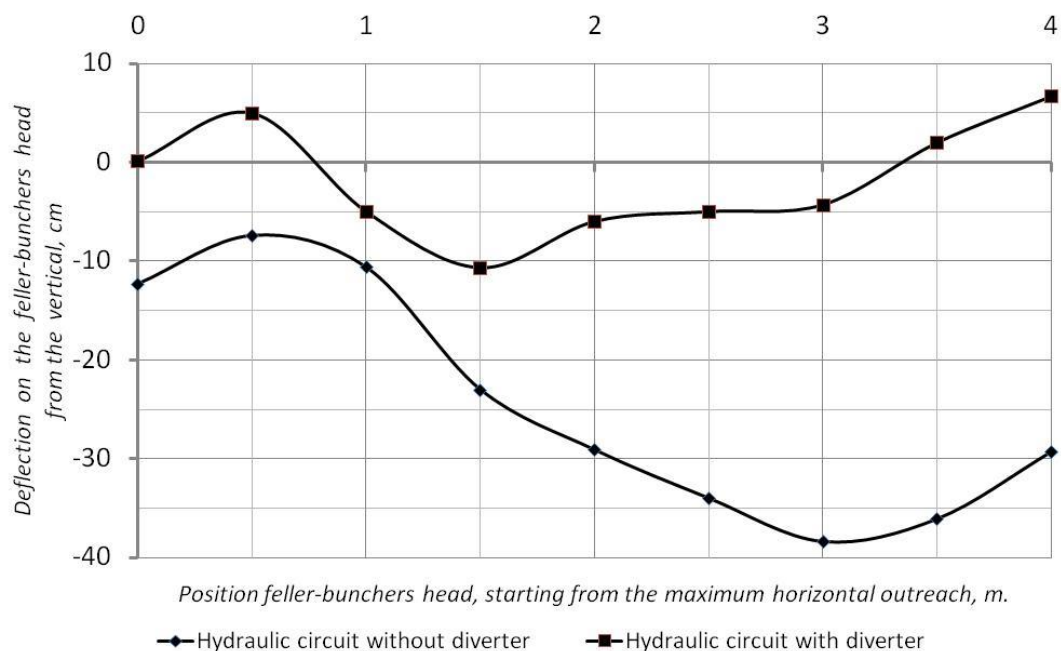

**Figure 9.** The dependence of the vertical movement of the feller-bunchers head FBM LP-19 when moving from maximum to minimum reach when using a hydraulic system without a diverter and with a diverter.

During the experiments, the duration of the aiming and pulling operations of the sawn tree was also recorded. The use of a diverter made it possible to reduce the time of the feller-bunchers head aiming operation (changing the horizontal outreach) from 13,2 sec. up to 7,7 sec.

In the process of performing experimental studies, it was initially adopted and subsequently, by comparing the calculated and tabulated Fisher coefficients, the normal distribution law of the measured quantities was confirmed (the calculated Fisher coefficient was smaller than the tabulated one).

Statistical processing of experimental data, taking into account the accuracy of the measuring instruments used, showed that in order to obtain reliable data, it is necessary to carry out at least 7 measurements of the vertical displacement of the feller-bunchers head at each point of the final and intermediate positions and at least 7 measurements of the aiming time of the feller-bunchers head from the position of minimum to the position of maximum horizontal outreach.

The use of hydraulic FBM LP-19 diverter, enabling the movement of the working body is close to parallel, reducing the time of implementation of the operation aiming feller-bunchers head FBM LP-19 (changing the horizontal outreach) from 13,2 sec. up to 7,7 sec.



#### 4. Conclusion

A mathematical model of the articulated manipulator FBM LP-19 has been developed that allows detecting the laws of motion of the boom and stick, as well as the stand feller-bunchers head, depending on the volume of the working fluid in the hydraulic cylinders of the boom and stick drive FBM LP-19.

Based on the results of mathematical modeling, a method and means for controlling the trajectory of the handle, arrow, and feller-bunchers head VPM LP-19 with one complex control device that ensures the movement of the feller-bunchers head close to a plane-parallel one by using a divertor.

The dependence of the position of the VPM LP-19 in the vertical plane on the horizontal outreach of the arrow and the stick when using the divertor and without its use was revealed.

The use of a divertor provides deviations from the vertical feller-bunchers head VPM LP-19 with horizontal movement of the arrow and stick in the range from + 5 to -11 centimeters.

The use of a divertor provides a relative reduction in the deviation from the vertical of the feller-bunchers head when the boom is moved horizontally in the range from 150 to 1600 % compared to the basic VPM LP-19.

It has been experimentally established that the use of a divertor reduces the time of the aiming operation of the feller-bunchers head VPM LP-19 (changing the horizontal outreach) from 13,2 *sec.* up to 7,7 *sec.*; provides a 17 % increase in VPM LP-19 performance.

When using the VPM LP-19, equipped with a divertor, it is necessary to provide the cut tree of at least 12 *sm* from the base to enable the smooth operation of pulling felled tree; in the case of elevations in the area of operation of the pickup and pull felled tree work required on the horizontal outreach feller-bunchers head not exceeding 0,8 *m*.

#### References

- [1] Zhang Z, Wang L and Shao Z 2018 Improving the kinematic performance of a planar 3-RRR parallel manipulator through actuation mode conversion *Mechanism and Machine Theory* **130** 86–108
- [2] Liu X, Li J and Zhou Y 2015 Kinematic optimal design of a 2-degree-of-freedom 3-parallelogram planar parallel manipulator *Mechanism and Machine Theory* **87** 1–17
- [3] Wu J, Wang L and You Z 2010 A new method for optimum design of parallel manipulator based on kinematics and dynamics *Nonlinear Dynamics* **61** 717–27
- [4] Ling M, Cao J, Pehrson N and Ling M 2019 Kinetostatic and dynamic analyses of planar compliant mechanisms via a two-port dynamic stiffness model *Precision Engineering* **57** 149–61
- [5] Chen Z and Kong M 2019 Integrated optimal design of a high-speed planar parallel manipulator *Proceedings of the Institution of Mechanical Engineers, Part C: Journal of Mechanical Engineering Science* **233** 2976–90
- [6] Zhang Y, Wei S, Li D et al. 2018 Geometric Modeling and Free-elimination Computing Method for the Forward Kinematics Analysis of Planar Parallel Manipulators *Journal of Mechanical Engineering* **54** 27–33
- [7] Xu Y, Liu Y, Yao J and Zhao Y 2015 Analysis of a novel lifting mechanism for forging manipulators *Proceedings of the Institution of Mechanical Engineers, Part C: Journal of Mechanical Engineering Science* **229** 528–37
- [8] Huang Z, Li Q and Ding H 2013 Kinematic influence coefficient and kinematics analysis *Mechanisms and Machine Science* **6** 135–62
- [9] Mi J, Bao H and Du J 2012 Synchronization control of planar 2-dof robot with redundant actuation *Advanced Materials Research* **468-471** 1414–20
- [10] Li H, Zhang Y and Dai J S 2011 Design optimization of parallel manipulators with required pose resolution *Proceedings IEEE International Conference on Robotics and Automation* pp 3952–7
- [11] Harton D, Laliberté T and Gosselin C 2019 Modelling, trajectory optimisation and prototyping of sequentially actuated manipulators *Robotica* **37** 281–99

- [12] Schreiber L-T and Gosselin C 2018 Kinematically redundant planar parallel mechanisms: Kinematics, workspace and trajectory planning *Mechanism and Machine Theory* **119** 91–105
- [13] Bedoustani Y B, Bigras P, Taghirad H D and Bonev I A 2011 Lagrangian dynamics of cable-driven parallel manipulators: A variable mass formulation *Transactions of the Canadian Society for Mechanical Engineering* **35** 529–42
- [14] Wang X, Baron L and Cloutier G 2008 Topology of serial and parallel manipulators and topological diagrams *Mechanism and Machine Theory* **43** 754–70
- [15] Zhang D and Wei B 2015 Advances and Issues on Dynamic Balancing of Parallel Mechanisms *IEEE International Conference on Mechatronics and Automation (ICMA)* pp 1548–54
- [16] Huaco Z A 2014 *Justification of parameters and modes of operation of the forest harvester manipulator* (Voronezh: Voronezh State Forestry Academy) p 147
- [17] Davydov S V 1987 *The rationale for the departure of the manipulator of felling and skidding machines* (Khimki: Research and Design Institute of Mechanization and Energy of the Forestry Industry) p 19
- [18] Girev A V, Shestakov Ya I and Bagautdinov I N 2014 Modernization of the capture-cutting device of the feller-bulking machine LP-19 *In the collection: Scientific progress - the creativity of young materials of the IX international youth scientific conference on natural sciences and technical disciplines* **3** pp 314–5