

EDN: EASTLQ

УДК 621.376.2+621.376.4].001.36

COFDM System: An Overview

Mhnd Farhan*

Baghdad University
Baghdad, Iraq

Received 26.08.2023, received in revised form 04.09.2023, accepted 11.10.2023

Abstract. This article compares the performance of two modulation techniques – quadrature phase shift keying (QPSK) and M-ary quadrature amplitude modulation (M-QAM) with $M=8, 16, 32,$ and 64 —in a coded orthogonal frequency division multiplexing system. As an error-correcting code, convolutional technology is employed. A vehicular channel with additive white gaussian noise (AWGN) is utilized for communication. According to simulation data, for QPSK and M-QAM, a coded orthogonal frequency division multiplexing system performs better than an uncoded one. Additionally, the system performs better with QPSK than it does with M-QAM. Additionally, when M rises, the performance declines.

Keywords: COFDM, performance analysis.

Citation: Mhnd Farhan. COFDM System: An Overview. J. Sib. Fed. Univ. Eng. & Technol., 2023, 16(8), 1026–1034.
EDN: EASTLQ



Система COFDM: обзор

Мхнд Фархан

Багдадский университет
Ирак, Багдад

Аннотация. В этой статье сравниваются характеристики двух методов модуляции – квадратурной фазовой манипуляции (QPSK) и M-арной квадратурной амплитудной модуляции (M-QAM) с $M = 8, 16, 32$ и 64 – в кодированном мультиплексировании с ортогональным частотным разделением. В качестве кода, исправляющего ошибки, используется сверточная технология. Для связи применен автомобильный канал с аддитивным белым гауссовским шумом (AWGN). Согласно данным моделирования, для QPSK и M-QAM кодированная система мультиплексирования

© Siberian Federal University. All rights reserved

This work is licensed under a Creative Commons Attribution-Non Commercial 4.0 International License (CC BY-NC 4.0).

* Corresponding author E-mail address: mhndfarhan@yahoo.com

с ортогональным частотным разделением работает лучше, чем некодированная. Кроме того, система работает лучше с QPSK, чем с M-QAM. Когда M увеличивается, производительность снижается.

Ключевые слова: COFDM, анализ производительности.

Цитирование: Мхнд Фархан. Система COFDM: обзор / Мхнд Фархан // Журн. Сиб. федер. ун-та. Техника и технологии, 2023, 16(8). С. 1026–1034. EDN: EASTLQ

1. Introduction

As per the Orthogonal Frequency Division Multiplexing (OFDM) standard, a single high-information rate stream is divided into several lower rate streams that are simultaneously delivered across a number of smaller sub-channels. By carefully selecting subcarrier separating, such as by setting the subcarrier splitting to correspond to the valuable image time frame, it is possible to achieve orthogonality in OFDM. The range of each subcarrier has an invalid at the middle repetition of each of the alternate subcarriers in the framework because the subcarriers are orthogonal.

Since it offers a significant reduction in balancing multi-sided quality compared to conventional correction processes, OFDM has gained more popularity in recent decades. Other interesting elements include combating inter-symbol interference (ISI) and inter-carrier interference (ICI), which causes the receiver's multifarious nature to decline. OFDM offers excellent phantom effectiveness, too. Additionally, OFDM is more resistant to recurrence-specific fading. Numerous recent published works have analyzed the OFDM system due to its exceptional benefits and broad uses [1–7].

A few obstacles exist for OFDM. The main disadvantage is that when the subcarriers are included intelligibly, an OFDM framework with a significant number of sub-carriers has a very high peak-to-average power ratio (PAPR). Furthermore, compared to single-carrier modulated systems, OFDM is more sensitive to Doppler spreading. Additionally, the transmitter and receiver oscillators' defects generate a stage commotion that affects how the framework operates.

The right frequency interleaving and coding are essential in order to take use of the respectable variation that multi-path fading provides. In most OFDM applications, coding thus becomes an integral component. Much study has focused on the appropriate encoder, decoder, and between leaver plan for data transmission using OFDM over fading environments, as in references [8–9]

Despite the fact that a lot of research has focused on the development and use of coded OFDM frameworks for frequency specific fading channels, only a small number of studies provide useful performance analyses of these frameworks because of the unclear nature of this problem. In this case, a frequency-selective quasi-static fading channel is taken into account. This is a logical assumption for an indoor wireless environment that exhibits multi-path fading but eventually exhibits mild alterations, characterized as semi-static. Contrary to coding in Additive White Gaussian Noise (AWGN) channels, where one dominant pair-wise error probability related to the minimum distance of a block code or the free distance of a convolutional code determines the performance of the framework, all pair-wise error probabilities in a fading channel are equal. coded OFDM system decrease as banter polynomial of the sign to-commotion proportion (SNR). Thus the strong association Chernobound will be excessively free at any extent of SNR when the block length is enormous. Persuaded by the exhibition examination happens on block blurring directs in [10], the arbitrary coding maximum cutoff points [11] and the

strong talk cut down limits [12] and moreover the possibility of fitting channel limit are completed for the presentation examination of coded OFDM structure.

2. COFDM System Model

The model of COFDM structure is showed up in Fig. 1. It is for the most part involving transmitter, recipient, and channel as a transmission way. These three areas are explained in focal points in resulting fragments [2].

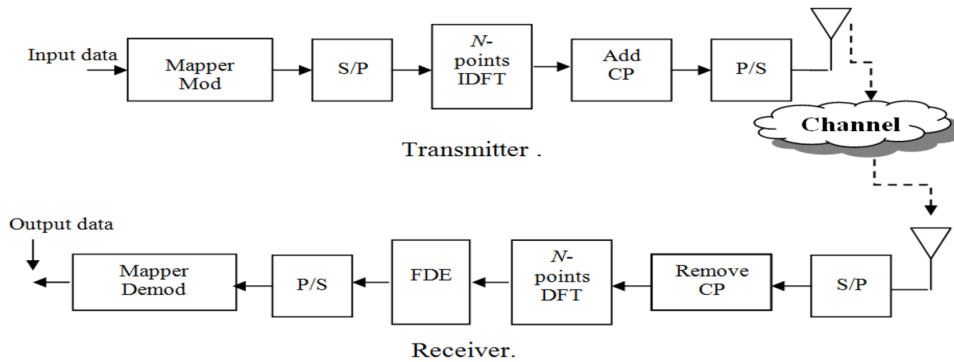

Fig. 1. Model of COFDM system

2.1. COFDM transmitter

The multi-transporter transmitter involves a game plan of modulators, each with different transporter frequencies. The transmitter by then unites the modulator yields and makes the communicated banner. Expect that the N data to be communicated are, $k = 0, 1, \dots, N-1$, where is an erratic number in a given quadrature sufficiency modulation(QAM) star grouping. Along these lines, the yield of tweak mapper takes any assessment of sixteen particular assessments of QAM heavenly body showed up in Fig. 2 [3], and [4].

The yield from regulation mapper is associated with sequential to resemble (S/P) transformation. The S/P changes over sequential information into N equal streams. In light of the S/P change, the

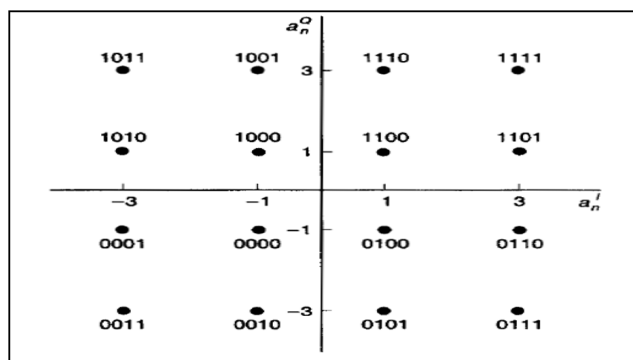

Fig. 2. 16-ary QAM constellation

length of transmission time for N images is connected with NT_s . Letting $t = n$, where is the example stretch, the high level multi-transporter transmitter yield is

$$X(nT_s) = \sum_{k=0}^{N-1} x_k e^{j2\pi f_k nT_s} \tag{1}$$

Furthermore, if the carrier frequencies are uniformly spaced in the frequency domain by a frequency spacing of f_s , $f_k = kf_s$, $k = 0, 1, \dots, N-1$, then

$$X(nT_s) = \sum_{k=0}^{N-1} x_k e^{j2\pi k f_s nT_s} \tag{2}$$

Equation (1) addresses the result of S/P transformation. Then, the equal information tests are taken care of to the reverse discrete Fourier change (IDFT) block to get the time space OFDM images.

Let $f_s = 1/(NT_s)$ which is the minimum separation to keep orthogonality among signals on different modulators, then the OFDM signal is given by:

$$X(n) = \sum_{k=0}^{N-1} x_k e^{j2\pi k(1/N)n} \tag{3}$$

The above recipe is the condition of a N -point IDFT. There are two copies of the got waveform, one on time and the other conceded by some time. ISI is provoked considering the way that the tail some piece of image 1 will intrude with the treatment of image 2. To clear out ISI, a screen timespan is for the most part implanted close to the beginning of each OFDM image [5], [6], and [7].

The cyclic prefix (CP) is a void ISI since it goes about as watch space between moderate images, it similarly change over the straight convolution with channel drive response into a cyclic convolution. As a cyclic convolution in the time space changes over into a scalar expansion in the repeat region, the subcarriers stay symmetrical. The CP is an exact of the last examples of the OFDM image into its front. Allow an opportunity to show the length of CP to the extent that samples, then the extended OFDM images currently have the range of $T_{sys} = T_{sub} + T_G$

Fig. 3 shows two nonstop OFDM images. The screen interval longer than the best deferral of the multipath channel (thinks about keeping up the symmetry among the subcarriers. As the soundness of each conceded subcarrier has been legitimate by the CP, its symmetry with all unique subcarriers is kept up got done. Exactly when the length of the safeguard interval (CP) is set more limited than the most outrageous delay of a multipath channel, the tail some part of an OFDM image impacts the head some piece of the accompanying image, achieving the ISI.

The output equation of the CP block is $\hat{x}(n) = x((n - L))_N$, where $n = 0, \dots, N+L-1$. Then the output from the CP block is applied to parallel to serial (P/S) conversion. The P/S converts parallel data into N serial streams [8], and [9].

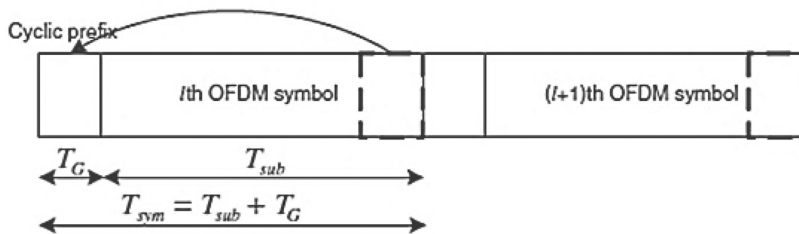

Fig. 3. OFDM symbols with CP

2.1.1. Convolutional code

A convolutional code is a kind of blunder revising code that produces equality images through the sliding utilization of a boolean polynomial ability to an information stream. The sliding application addresses the 'convolution' of the encoder over the information, which offers climb to the term 'convolutional coding.' The sliding thought of the convolutional codes energizes lattice unraveling using a period invariant lattice. Time invariant lattice translating licenses convolutional codes to be most outrageous likelihood fragile decision decoded with reasonable complexity.

The ability to perform moderate most outrageous greatest probability decision disentangling is one of the critical benefits of convolutional codes. This is rather than exemplary block codes, which are generally addressed by a period variation lattice and in this manner are typically hard-decision decoded. Convolutional codes are consistently depicted by the base code rate and the profundity (or memory) of the encoder $[n, k, K]$. The base code rate is usually given as n/k , where n is the information rate and k is the result image rate. The profundity is much of the time called the "imperative length" 'K', where the yield is a part of the current information and furthermore the previous $K-1$ data sources. The profundity may in like manner be given as the amount of memory parts 'v' in the polynomial or the best possible number of states of the encoder (generally 2^v) [9].

Convolutional codes are often portrayed as relentless. Anyway, it could moreover be said that convolutional codes have erratic block length, rather than being steady, since most certifiable convolutional encoding is performed on blocks of information. Convolutionally encoded block codes consistently use end. The inconsistent block length of convolutional codes can moreover be separated to extraordinary block codes, which generally have fixed block lengths that are directed by logarithmic properties.

The code pace of a convolutional code is for the most part changed through image penetrating. For example, a convolutional code with a 'mother' code rate $n/k=1/2$ may be penetrated to a higher pace of, for example, $7/8$ essentially by not sending a piece of code images. The exhibition of a penetrated convolutional code overall scales well with the proportion of equality sent. The ability to perform saving fragile decision translating on convolutional codes, and what's more the block length and code rate versatility of convolutional codes, spreads the word about them very well for advanced correspondences [10].

2.2. Communication channel

To simplify the mathematical analysis, a time-invariant channel is assumed which has the following response with R taps

$$h^T = [h_0 \ h_1 \ \dots \ h_{R-1}] \quad (4)$$

The channel impulse response is circularly convolved with the transmitted signals owing to the CP in OFDM signals, so the output of the channel will be as follows

$$\begin{aligned} y(n) &= h(n) * \overline{x(n)} + N(n) \\ y(n) &= h(n) * x((n-L))_N + N(n) \\ y(n) &= h(n)x(n) + N(n) \end{aligned} \quad (5)$$

The output of the channel (i.e. the received signal) can be written in matrix form as follows [10]:

$$Y = \begin{bmatrix} \overbrace{0 \ \dots \ 0}^{N_F-R+1} \ h_{R-1} \ h_{R-2} \ \dots \ h_0 & \overbrace{0 \ \dots \ 0}^{N-1} \\ 0 \ \dots \ 0 \ h_{R-1} \ h_{R-2} \ \dots \ h_0 & \dots \ 0 \\ \dots & \dots \\ 0 & \dots \ 0 \ h_{R-1} \ h_{R-2} \ \dots \ h_0 \end{bmatrix} = X + N \quad (6)$$

2.3. COFDM receiver

At the receiver end, firstly, the received signal is applied to S/P conversion. The S/P converts serial data into parallel streams. Then the received signals $Y = [y_0 \ y_1 \ \dots \ y_{N-1}]^T$ after removal of the CP can be expressed as:

$$Y = \begin{bmatrix} h_0 & 0 & \dots & 0 & h_{R-1} & h_{R-2} & \dots & h_1 \\ h_1 & h_0 & 0 & \dots & 0 & h_{R-1} & \dots & h_2 \\ \dots & \dots & \dots & \dots & \dots & \dots & \dots & \dots \\ h_{R-1} & h_{R-2} & \dots & h_0 & 0 & \dots & \dots & 0 \\ 0 & h_{R-1} & \dots & h_1 & h_0 & \dots & \dots & 0 \\ \dots & \dots & \dots & \dots & \dots & \dots & \dots & \dots \\ 0 & \dots & \dots & 0 & h_{R-1} & \dots & \dots & h_0 \end{bmatrix} \begin{bmatrix} x_0 \\ x_1 \\ \dots \\ \dots \\ \dots \\ \dots \\ x_{N-1} \end{bmatrix} \quad (7)$$

$$Y = QX + N$$

where x consists of the last N elements in X and N is the Gaussian noise. Note that the circulant matrix Q can be diagonalized by the DFT and IDFT matrices, yielding

$$Q = F^{-1}HF \quad (8)$$

where F and F^{-1} are the DFT and IDFT matrices, respectively. The matrix H is a diagonal matrix:

$$H = \begin{bmatrix} H_0 & 0 & \dots & 0 \\ 0 & H_1 & \dots & 0 \\ \vdots & \vdots & \ddots & \vdots \\ 0 & \dots & 0 & H_{N-1} \end{bmatrix} \quad (9)$$

where every askew component relates to the recurrence space channel reaction at the comparing subcarrier.

Note that OFDM changes over the convolution in time region into expansion in recurrence area and subsequently fundamental one-tap recurrence space balancers can be used to recover the sent images. After DFT, images are demodulated and decoded to procure the communicated information bits by demodulation mapper [11–14]

3. Simulation Results

Maltlab 2017 is used to mimic the COFDM system, with modulation methods like QPSK, 8-QAM, 16-QAM, 32-QAM, and 64-QAM. Convolutional code is integrated with the model with the intention of enhancing the framework’s execution; as a result, the OFDM is referred to as coded OFDM (COFDM). It is decided to use a convolutional code with an octal generating polynomial of length 7 (133,171). Vehicle channel with 11 ways is the channel display in use. Table 1 contains a list of the reproduction-related parameters.

Table. 1 COFDM Simulation Parameters

Value	Parameter
512	FFT Size
20Samples	Cyclic Prefix Length
24.41 ns	Time between Samples
Convolution Code with Rate=1/2	Channel Coding
QPSK, 8-QAM, 16-QAM, 32-QAM, and 64-QAM	Modulation Types
Vehicular Channel with 11Paths	Channel Model

Bit-error-rate (BER) vs signal-to-noise ratio (SNR) measurements are used to assess how well the overall system is working. The execution of the framework for an uncoded system is shown in Fig. 4 and 5, respectively. It appears that a coded system performs better than an uncoded system. Additionally, QPSK performs better than M-QAM, and the performance declines as M grows.

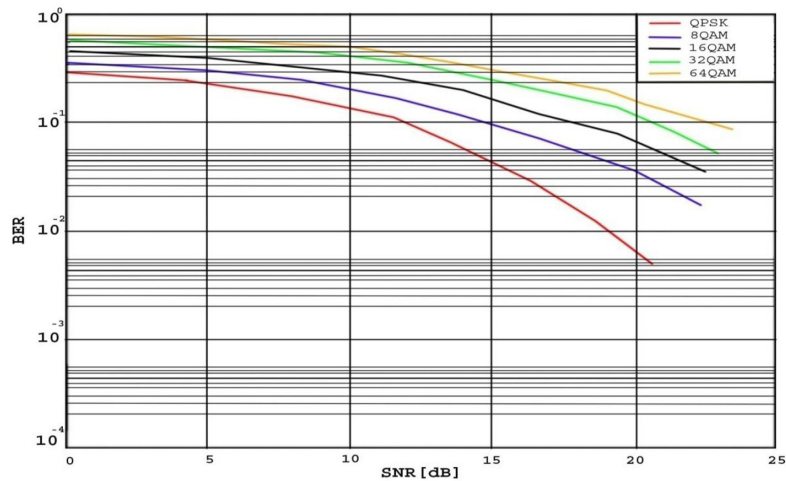

Fig. 4. BER performance of un-coded OFDM over multipath fading channel

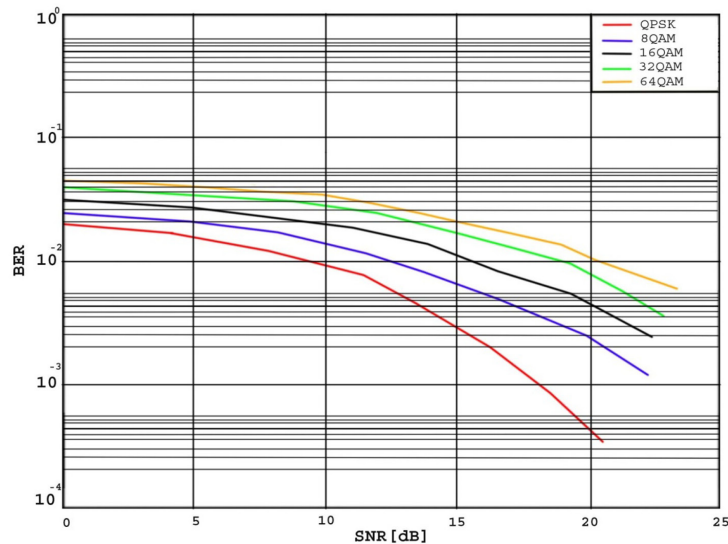

Fig. 5. BER performance of COFDM over multipath fading channel

4. Conclusion

To investigate the performance of the COFDM system over the vehicular channel with AWGN utilizing QPSK, 8-QAM, 16-QAM, 32-QAM, and 64-QAM, a model of the system was created. As an error-correcting code, convolutional technology was employed. The outcomes demonstrate that COFDM performs better than un-coded one. Additionally, QPSK offers superior performance than M-QAM. Additionally, the performance suffers as M increases.

References

- [1] Bingham J. Multicarrier Modulation for Data Transmission: An Idea Whose Time Has Come. *IEEE Commun. Mag.*, 2(5), May, 1990, 5–14.
- [2] LeFloch B., Alard M. and Berrou C. Coded Orthogonal Frequency Division Multiplex. *Proc. IEEE*, 83, June, 1995, 982–96.
- [3] Stephen B. History of OFDM. *IEEE Commun. Mag.* 47(11), Nov., 2009, 26–35.
- [4] Sharma V. BER performance of OFDM-BPSK, -QPSK, – QAM over AWGN channel using forward Error correcting code. *International Journal of Engineering Research and Applications*. 2(3), 2012, 1619–1624.
- [5] Khan Y. To Improve Performance of OFDM System Using Optimize Adaptive Coding Technique with Convolutional and BCH Coding. *International Journal of Application or Innovation in Engineering & Management*. 3(5), May 2014.
- [6] Alex B. Behavior and Techniques for Improving Performance of OFDM Systems for Wireless communications. *International Journal of Advanced Research in Computer and Communication Engineering*. 4(1), January 2015.
- [7] Sachin. Analyzing the BER Performance of OFDM-System with QPSK and BPSK Modulation Technique. *International Journal of Innovative Research in Advanced Engineering*. 2(6), 2015.

[8] Lu B., Wang X. and Narayanan K.R. LDPC-based space-time coded OFDM systems over correlated fading channels: Performance analysis and receiver design. *IEEE Trans. Wireless Commun.* 1. 213–225, 2002.

[9] Kim H. Turbo coded orthogonal frequency division multiplexing for digital audio broadcasting. In *2000 IEEE Intern. Confer. on Commun.* 1, 420–424.

[10] Malkamaki E. and Leib H. Coded diversity on block-fading channels. *IEEE Trans. Inform. Theory.* 45, 771–781, 1999.

[11] Gallager R. G. *Information Theory and Reliable communication.* New York, Wiley, 1968.

[12] Arimoto S. On the converse to the coding theorem for discrete memoryless channels. *IEEE Personal Commun.* IT-19, 357–359, 1973.

[13] Al-Awad N. and Al-Rawi M. On the Performance of COFDM System. *International Journal of Open Information Technologies.* 6, 39–42, 2018.

[14] Liu M., Shen W., Yan J. and Zeng H. A Simulation Method of Orthogonal Frequency Division Multiplexing. *2022 14th International Conference on Computer Research and Development (ICCRD)*, Shenzhen, China. 388–393, 2022.