

# Vibration damper-calibrator for shock wave damping from sharp bit installation on the bottomhole

K A Bashmur<sup>1</sup>, A V Zagulyaev<sup>1</sup>, E A Petrovsky<sup>1</sup>, V V Bukhtoyarov<sup>1,2</sup> and V V Kukartsev<sup>1,2</sup>

<sup>1</sup>Siberian Federal University, 79, Svobodny Av., Krasnoyarsk, 660041, Russia

<sup>2</sup>Reshetnev Siberian State University of Science and Technology, 31 Krasnoyarsky Rabochy Av., Krasnoyarsk, 660037, Russia

E-mail: shura.zagulyaev@mail.ru, bashmur@bk.ru

**Abstract.** This article addresses the problem of drill string vibration. In particular, the issue of quenching of high-amplitude low-frequency vibrations generated from sharp installation of the bit on the bottomhole is analyzed. This problem is virtually uncontrolled and arises from objective factors such as rock collapse and subjective factors such as driller error. It is proposed to use impact type of vibration damper for damping of this type of vibration. Possible design of well impact vibration damper-calibrator is shown. A dynamic model of the vibration damper has been built. Analysis of the model suggests the efficiency of using these types of vibration dampers to eliminate high-amplitude low-frequency vibrations of drill columns.

## 1. Introduction

Technical and economic characteristics of drilling, durability and reliability of downhole tool, operating conditions of drilling tool and working elements of drilling string bottom arrangement depend significantly on intensity of longitudinal oscillations occurring during drilling of oil and gas wells [1].

The most dangerous types of oscillations are the oscillations of the bit caused by the slackness of the well face. The effect of falling the drill string (DS) when the bit falls into the formed collars is created. The impact of vibrations is particularly great when drilling hard and hard rocks with rolling bits, as the grooviness of the well face increases. In this regard, the task of protecting instruments and equipment, in particular DS protection, from vibration and shock impacts [2] becomes relevant.

The main source of excitation of vibrations in drilling is interaction of the bit with rock, as well as: DS rotation; boring pumps; stabilizers, etc. Interaction of bits with rock can cause longitudinal or slip vibrations depending on the type of bit, which are further transmitted to DS, as well as are transformed into other types of vibrations [3, 4]. High amplitude impact load occurs also in case of sharp DS decision on well bottom [2].

Application of vibration dampers has the ultimate goal of increasing stability of bit, DS elements, improving control over drilling process, increasing service life of ground equipment, providing the specified drilling mode, increasing pass-through per run and increasing efficiency of drilling operations as a whole [1, 5].

Among dynamic vibration dampers, shock principle vibration dampers are actively developing in recent decades [6]. Vibration shock dampers include devices, in which vibration damping method consists in transfer of kinetic energy of relative movement of contacting elements into energy of

deformation with propagation of vibrations from contact zone over interacting elements. As a result, energy is distributed over the volume of the impinging elements of the vibration damper, causing their vibrations and at the same time dissipating energy due to external and internal friction forces. The use of shock dampers has already been proposed for damping lateral DS vibrations [7]. The method of damping torsional DS vibrations by means of energy dissipation of impact masses is also known [8]. There is also known impact vibration DS damper based on interaction of magnetic fields [9], but application of magnets in the well is limited by possible external environment. The latter can be said about shock absorbers, elastic elements and liquid in which depend on the external environment and require regular maintenance [10].

**2. The developed vibration damper-calibrator design**

Shock dampers are better used for high-amplitude loads caused by shocks or shakes, for example, during round-trip operations or by sharp bottoming of a bit. Based on these findings, a design (Pat. No. RU 2533793) of vibration shock damper was elaborated (figure 1).

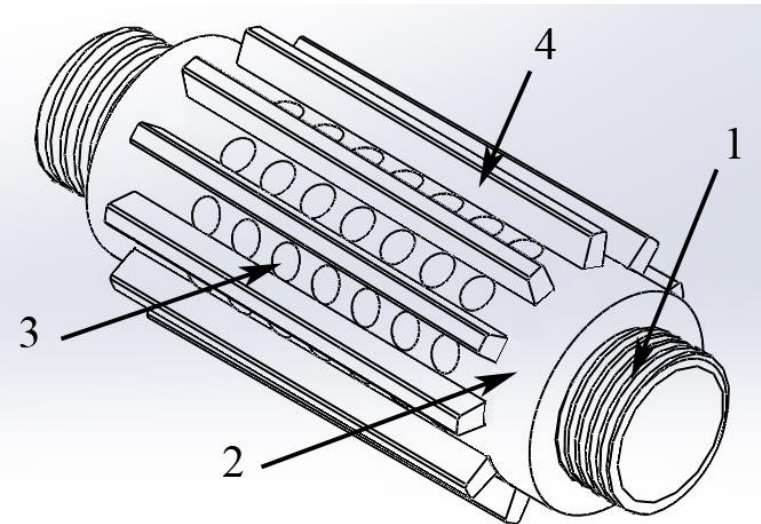

**Figure 1.** Vibration damper-calibrator: 1 – housing; 2 – plug; 3 – metal balls; 4 – hard alloy ribs.

The resulting longitudinal shocks and vibrations from the bit receive the housing 1 with the outer bushing 2 forming the holder. Metal balls 3 are installed in the holder. When vibration waves occur, vibrations are suppressed due to dissipative forces of moving balls 3, which provide impact suppression of vibrations in longitudinal direction in phase from ball to ball, which is possible due to difference in diameter of balls, and therefore, mass of balls 3 and difference in gaps between them. Balls return to initial position due to gravity. At the same time parts of energy are transferred to bushing 2 with hard-alloy ribs 4 for formation of borehole wall. Balls 3 are lubricated with drilling fluid, which increases logarithmic decertification of vibration attenuation at impact damping of vibrations, dissipation of vibration energy due to liquid friction of balls 3, as well as their smooth return to initial position.

This vibration damper differs from other equipment of vibration protection of drilling equipment in durability of operation, and as a result, cheap, weak effect of medium on operation of vibration damper, as well as transfer of vibration energy to formation of borehole walls.

**3. Dynamic model of vibration damper-calibrator**

In vibration damper-calibrator of impact action, longitudinal vibrations are suppressed due to dissipative forces at impact of metal balls [11], in our case moving in longitudinal direction in phase from ball to ball. In order to estimate the efficiency of vibration damping, it is necessary to calculate the amount of

energy dissipated per impact of metal balls. Diagram of balls impact and distribution of their speeds is given in figure 2.

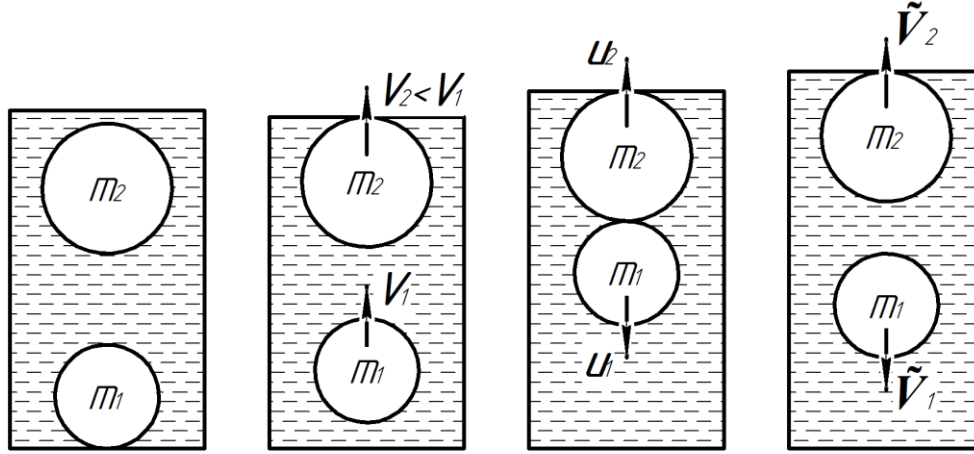

**Figure 2.** Diagram for calculation of ball speeds in vibration damper.

For the initial cause of ball movement we take force  $F = F_m \sin \omega t$ , which drives all balls at the same time and then there is a chain of collisions of the latter, starting from the first one. Under Newton's second law, acceleration for the first ball is

$$x_1'' = \frac{F_m}{m_1} \sin \omega t - g \quad (1)$$

where:  $F_m$  – vibration amplitude, N;  $m_1$  – mass of the first ball, kg;  $\omega$  – cyclic frequency of oscillations,  $s^{-1}$ .

The origin is located in the center of the first ball, then the initial conditions will be  $x(0) = 0$ ,  $x'(0) = v_1$ , where  $v_1$  is the speed of the first ball immediately after the impact of the external force  $F$ .

$i$ -th ball will get speed at the initial moment of time

$$v_i = \frac{F_{mid} \Delta t}{m_i} \quad (2)$$

where:  $\Delta t$  – time of force  $F$  action and  $F_{mid}$  is its average value at the moment of impact on the vibration damper.

With this in mind, taking the derivative according to the solution of equation (1)

$$v_1(t) = x_1'(t) = -\frac{F_m}{m_1 \omega} \cos \omega t - gt + v_1 + \frac{F_m}{m_1 \omega} \quad (3)$$

Our task is to find the speed of balls after a chain of all impacts, then their kinetic energy. The proportion of this energy to the energy of the balls prior to impact will characterize the efficiency of vibration damping by this vibration damper-calibrator.

The second ball motion equations in the same coordinate system will have initial conditions  $x(0) = R_1 + R_2 + d_1$  и  $x'(0) = v_2$ , where  $R_1$  и  $R_2$  are the radii of the first and second balls;  $h_1$  – initial clearance between them. The equations will take a form

$$x_2(t) = -\frac{F_m}{m_2 \omega^2} \sin \omega t - \frac{gt^2}{2} + t \left( v_2 + \frac{F_m}{m_2 \omega} \right) + R_1 + R_2 + h_1 \quad (4)$$

$$v_2(t) = -\frac{F_m}{m_2 \omega} \cos \omega t - gt + v_2 + \frac{F_m}{m_2 \omega} \quad (5)$$

Numerical data for calculating vibration energy dissipation are shown in table 1.

**Table 1.** Numerical data to calculate vibration energy dissipation.

Parameter	$m_1$ , kg	$m_2$ , kg	$F_m$ , N	$h_1$ , m	$\Delta t$ , s	$\omega$ , Hz
Value	0.05	0.10	100	0.01	0.01	50

The forced oscillation frequency  $\omega$  should not be greater than the  $2\pi/T$  value, where  $T$  is the time during which the first ball will collide with the second ball and return. Taking into account the data of Table 1, we get

$$x_1(t) = -0.8\sin 50t - 4.9t^2 + 50t \quad (6)$$

$$v_1(t) = -40\cos 50t - 9.8t + 50 \quad (7)$$

$$x_2(t) = -0.4\sin 50t - 4.9t^2 + 25t + R_1 + R_2 + 0.01 \quad (8)$$

$$v_2(t) = -20\cos 50t - 9.8t + 25 \quad (9)$$

We find now time  $t_1$  through which the first and second balls will collide. This time can be found from condition  $x_2(t_1) - x_1(t_1) = R_1 + R_2$ . We have

$$x_2(t_1) - x_1(t_1) = 0.4\sin 50t - 25t + R_1 + R_2 + 0.01 = R_1 + R_2 \quad (10)$$

from where

$$0.4\sin 50t - 25t + 0.01 = 0 \quad (11)$$

This transcendental equation has root  $t_1 \approx 0.002$  s – it is time through which there will be an impact of the first and second spheres. Their speeds immediately at the moment of impact  $v_2(t_1) = 10.18$  m/s and  $v_1(t_1) = 5.08$  m/s.

Now we find the speed of the second ball  $u_2$  immediately after the impact through the law of momentum preservation

$$u_2 = \frac{m_1 v_1 + m_2 v_2 + k m_1 v_1}{m_2} = 13,02 \text{ m/s} \quad (12)$$

where  $k$  – coefficient of recovery after impact ( $k = 0.56$  for steel).

After that, the first ball will begin to fall to the initial position, and the second will continue to fly at a higher speed to the third ball. The second ball motion equation will be described by the same differential equation, but already with other initial conditions. We will sign the speed and movement of the  $i$ -th ball after impact with the previous one, as  $\tilde{v}_i$  and  $\tilde{x}_i$  accordingly.

We take the balls hollow with the wall thickness equal to half their radius, then  $R_1 = 0.01$  m and  $R_2 = 0.015$  m. Then the solution of equation (1) for the second ball with initial conditions  $\tilde{x}_2(0) = R_1 + R_2 + 0.01 + x_2(t_1)$  and  $\tilde{x}'_2(0) = u_2$  will be

$$\tilde{x}_2(t) = -0.4\sin 50t - 4.9t^2 + 18.02t + 0.08 \quad (13)$$

$$\tilde{v}_2(t) = -20\cos 10t - 9.8t + 18.02 \quad (14)$$

That is, the second ball before impact with the first had a law of movement different from the first due to changed initial conditions. Then it will fly to the third ball, which at this moment already a little flew to some point, will collide with it, the third will fly to the fourth, etc.

If the masses of 3, 4 and 5 balls are equal to 0.15, 0.2 and 0.5 kg, respectively, we will get the speeds after impact  $u_3 = 8.7$  m/s,  $u_4 = 5.2$  m/s and  $u_5 = 4.1$  m/s. By approximating the speeds of balls after least squares impact, an exponential relationship can be identified

$$u(n) = 28.241e^{-0.398n} \quad (15)$$

According to this relationship, the speed of the 6th ball after impact will be  $u_6 = 2.59$  m/s, which is well consistent with the calculation data.

Now we will find the share of energy that will be extinguished as a result of operation of the damper-calibrator. The energy supplied to the vibration damper went to the kinetic energy of the initial take-off of the balls

$$W = \sum_{i=1}^n \frac{m_i v_i^2}{2} \quad (16)$$

For convenience, it will be assumed that from the bottom up the mass of balls increases linearly. Considering that the masses of the first five balls 0.05, 0.1, 0.15, 0.2, 0.25 kg, the following linear relationship can be detected

$$m(n) = 0.05n \quad (17)$$

Speed  $v_i$  is determined by equality (2). Having substituted data, we will find

$$W = \sum_{i=1}^n \frac{2.5}{i} \quad (18)$$

We received a harmonious row. Useful energy taking into account (15) and (17)

$$W_n = \sum_{i=1}^n \frac{1}{2} 0.05i (28.241e^{-0.398i})^2 \quad (19)$$

The share of dissipated energy will be found as

$$\alpha = \frac{W}{W_n} \quad (20)$$

Set to (20) equals (18) and (19), we get

$$\alpha = \frac{\sum_{i=1}^n 0.798i \exp(-0.796i)}{\sum_{i=1}^n 1/i} \quad (21)$$

In general, it is difficult to calculate these amounts without using special methods, so we will limit ourselves to graphical representation (figure 3).

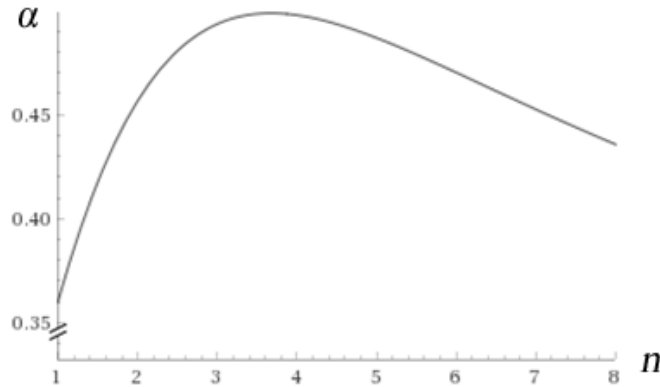

**Figure 3.** Graph of the ratio of the dissipation energy to the number of balls.

#### 4. Conclusion

Thus, dynamic simulation has found that the vibration damper-calibrator performs its function in full. The proportion of dissipated vibration energy increases as the number of balls used increases to three, and then begins to fall, as the speeds of the upper balls after impact become smaller and smaller up to zero and the useful energy stops growing, unlike the supplied energy. Installation of shock-type vibration dampers looks most successful at low-frequency, high-amplitude oscillations. For example, in a bottom arrangement of a drill string for vibration wave protection against sharp bottoming of a bit. The use of

impact type vibration dampers will reduce damage to drill pipes, well tools and damage to pipe connections by reducing impact loads from the bit.

### References

- [1] Bashmur K A et al 2019 *J. Phys.: Conf. Ser.* **1353** 012039
- [2] Yanturin A Sh 1988 Advanced Operation Methods and Mechanics of the Drill String [in Russian – Peredovyye metody ekspluatatsii i mekhanika burilynoy kolonny] *Bashk. kn. izd-vo*
- [3] Zhang Y L 1990 *Soc. Petr. Eng.* 20325
- [4] Wilson J K, Noynaert S F 2017 *Soc. Petr. Eng.* 184635
- [5] Márquez M B S, Boussaada I, Mounier H and Niculescu S-I 2015 Analysis and Control of Oilwell Drilling Vibrations *Springer Int. Publish.*
- [6] Gharib M, Ghani S 2013 *J. Sound Vib.* **332** 6254–64
- [7] Hu L, Palazzolo A, and Karkoub M 2016 *J. Vib. Acoust.* **138(5)** 051013
- [8] Velichkovich A S, Velichkovich S V 2001 *Chem. Petrol. Eng.* **37** 213–5
- [9] Bukhtoyarov V V et al 2018 *Int. Multidisciplinary Scientific GeoConf. Surveying Geology and Mining Ecology Management (SGEM 2018)* **18(1.4)** 573–81
- [10] Liu Y et al 2016 *Shock Vib.* **2016** 2041671
- [11] Bapat C N 1988 *J. Sound Vib.* **120(1)** 53–61