

УДК 537.312.9

Aluminum Busbar Connection Parts of the Cell «Flexible Cathode Descent – Cathode Bus»

Vladimir I. Kirko^{a*},

Takhir T. Galemov^b and Alexandr M. Petrov^c

*^aKrasnoyarsk State Pedagogical University them. VP Astafeva,
89 Ada Lebedeva Str., Krasnoyarsk, 660049 Russia*

*^bSiberian Federal University,
79 Svobodny, Krasnoyarsk, 660041 Russia*

*^cETC Co Ltd «United Company RUSAL»,
37 Pogranichnikov Str., Krasnoyarsk, 660111 Russia*

Received 15.06.2013, received in revised form 24.06.2013, accepted 30.07.2013

In the given article we present our results of research of aluminum joint parts of «cathodic flexible with a cathode bus». Basing on the theoretical analysis and experimental researches, we present the method of molding of joint assemblies in the casting mould, with an overheated fusion. The suggested method let us produce a high-quality junction without loss of electrolyser's series productivity and it also allows decreasing the operational expenditures.

Keywords: resistivity, pressure, contact, detachable joints, aluminum cell busbar.

Introduction

In metallurgy where multiwatt electric power installations are being used there is a nagging problem of decreasing energy losses at the electric power transmission from a source to the consuming installation [1, 2]. The main losses take place at electric contacts in particular at the power transmission from the aluminum cell busbar to flexible cathode strips (cathodic flexibles).

At present after the repair work one has to use 2 basic methods for connecting a cell to the series power circuit of the cell shell:

1. Electric-arc welding in argon of the preliminarily formed aluminum boss and cathodic flexible to the busbar (Fig. 1).
2. Forming a boss connecting the busbar and flexible by filling a mould preliminarily fastened to the busbar surface with molten aluminum followed by heating the metal up to 1000 °C with the carbon electrode arc and agitation, whereupon the aluminum crystallizes and forms the contact joint between the flexible and busbar.

In strong magnetic fields the presence of a potential leads to a part of the technological electrolysis current flowing through the molten metal (the weldpool) connecting the busbars. The interaction of the

© Siberian Federal University. All rights reserved

* Corresponding author E-mail address: director.nifti@mail.ru

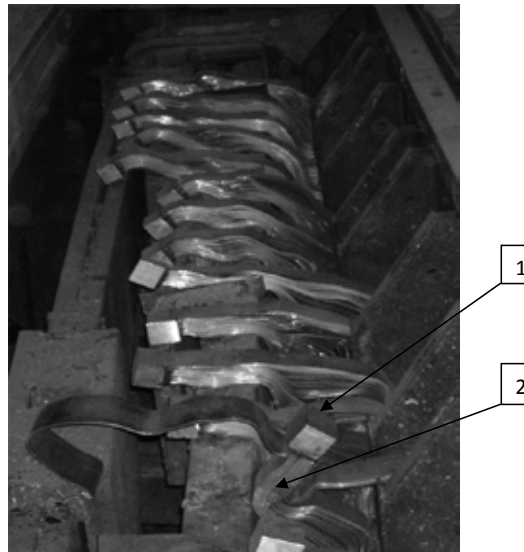

Fig. 1. Preliminarily formed aluminum bosses (1) on cathodic flexibles (2) before connecting to the cathode busbar with electric-arc welding in argon

magnetic field with certainly directed transverse components of the external electric field forms a force throwing the liquid metal out of the welding zone.

The methods above don't give an opportunity for quality welds on an operating cell busbar without stopping the bath or decreasing its current loading that leads to the loss of productivity of the potline and finally aluminum output decrease.

One of the most efficient methods to weld aluminum details in strong magnetic fields without electric-arc welding is that used by the firm Erico International Corporation of Solon, Ohio, USA, with the trademark ERICO [3]. The welding method is schematically represented in Fig. 2.

In the casting mould 1 there is loaded a mixture of an adding material and aluminum 3. There is used an exothermal reaction as follows: reducing agent + adding materials + metallic compound = heat + weld metal + slag + gases.

An aluminum powder is used as the reducing agent that can reduce a metal oxide (CuO) or its sulfate with the formation of Al_2O_3 . In the process there is released 400 kcal/mol of heat. This reaction is highly exothermal. And when it is initiated the temperature of the adding metals is higher than their melting points. The adding materials form a melt directed into the melting cavity (into the mould) after the aluminum plate 5 has been melted. The melt fills the melting cavity between the busbars 2. And after crystallization it provides a good weld of the busbars being connected.

The method above can be effectively used when welding cathodic flexibles but has sufficient disadvantages. Firstly, details of graphite moulds are costly and short-lived. Secondly, a high price of adding and igniting materials and their high consumption limit the massive usage of the technology. Thirdly, when the exothermal reaction proceeds there is emitted a large amount of gases (Fig. 3). The latter prevents the method to be used in an indoor working area.

Some examples of the ropes (a), plates (b) and flexibles (c) welds by means of the aluminothermic welding by ERICO are presented in Fig. 4.

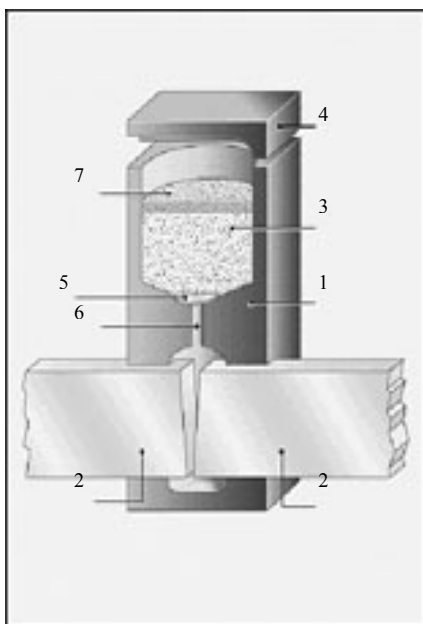

Fig. 2. Schematic diagram of aluminum busbars welding (ERICO): 1 – the casting mould; 2 – aluminum busbars; 3 – a mixture of an adding material and aluminum; 4 – a cover; 5 – an aluminum plate; 6 – a melting cavity; 7 – an igniting material (igniter)



Fig. 3. Aluminum busbars welding with the method by ERICO

As has been noted above at present in smelters of the «RUSAL» company there are widely used two welding methods:

1. Electric-arc welding in an inert gas (argon).
2. Carbon-arc welding.

The photographs of the typical flexibles to busbar welds are presented in Fig. 5.

In both cases because of the arc instability in strong magnetic fields it is necessary either to decrease the current loading in the potline or redistribute the busbar current during the welding process. The former and the latter have an adverse effect on the baths operation leading to their productivity decrease.

The common feature of all these welding methods is the overheated adding material compared to the aluminum with its melting point 658 °C.

In case of the aluminothermic welding the adding material temperature is about 1600 °C. When using the carbon-arc welding the cathodic flexible ends are fastened to the busbar and the mould is formed around them. The molten metal poured into the mould is heated up to 1000 °C with the carbon electrode arc and mixed for the oxide film removal from the surface of the details being connected followed by the molten aluminum crystallization that causes the contact joint between the flexibles and busbar to be formed.

Using the overheated metal witnesses the fact that a partial melting of the surfaces of the flexibles and busbar being connected through the aluminum oxide layer Al_2O_3 is the necessary welding condition. A good weld of two surfaces is possible only in case of the Al_2O_3 layer being destroyed.

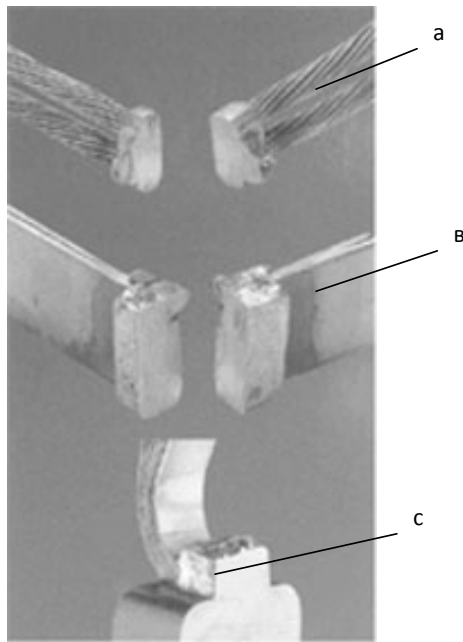

Fig. 4. Examples of the ropes (a), plates (b) and flexibles(c) welds with the method by ERICO



Fig. 5. Typical flexibles to busbar welds

In paper [4] there has been shown that the equilibrium limiting wetting angle of the monocrystal Al_2O_3 by the liquid aluminum steadily decreases with a temperature increase. Wetting ($Q = 90^\circ$) begins taking place at a temperature higher than $T_p = 1050^\circ\text{C}$. In Fig. 6 there is presented a temperature dependence of the angle for the Al_2O_3 monocrystal wetted with the molten aluminum.

Thereupon, the best thermal contact with the oxide film surface preventing the possibility of an air interlayer formation will be provided at the melt temperature $T_p > 1050^\circ\text{C}$.

Moreover, as is generally known, aluminum oxide has several modifications the main ones of which are g-phase having the cubic syngony and density $3.63.77\text{ g/cm}^3$ and α -phase having the orthorhombic or hexagonal syngony and density 4 g/cm^3 . The phase transition of the g – to the α -phase begins at the temperature 1200°C and ends at $T_i^{a@g} = 1400^\circ\text{C}$. Decreasing the phase transition temperature can occur to 800°C in presence of fluorides such as AlF_3 . Decreasing the specific volume

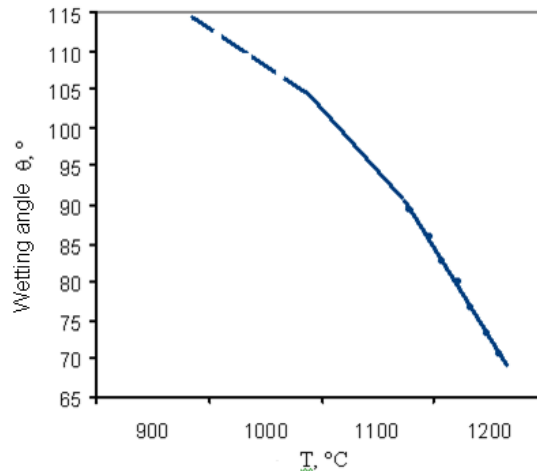

Fig. 6. Wetting angle vs. temperature for the Al_2O_3 monocrystal wetted with the molten aluminum

of a part of the oxide film also contributes to its brittle rupture due to the occurrence of negative internal stress.

Has been shown that the metal melting underneath the oxide film is the requirement for its destruction. The latter, as follows from thermodynamic calculations, is possible at the temperature of the poured melt $T \geq 1100$ °C.

Thus, there can be made a conclusion that the required melt temperature for the melting of the aluminum busbar's and flexible's surfaces depends on the thermalphysic conditions in the molten pool (in the mould).

When pouring the melt onto a boss some strongly turbulent flow conditions take place in the molten pool with the Reynolds number $\text{Re}=10^6$ and magnetic Reynolds number $\text{Re}_m > 10$. $\text{Re}_m \gg 1$ in the molten pool is the evidence of a strong influence of the magnetic field induced by the current in the busbar and prevailing influence of the magnetic viscosity in the formation of the hydrodynamic flow. In this case the boundary layer thickness δ_n between the melt and oxide film equals [3]:

$$\delta_n = \frac{1}{B} \sqrt{\frac{\eta_p}{\sigma_p}}, \quad (1)$$

where B – the magnetic field induction, η_p – the dynamic viscosity of the melt, σ_p – the conductivity of the melt.

For $B = 10^{-3} T (100 G)$; $\eta_p = 0,574 \cdot 10^{-3} \text{ Pa s}$ and $\sigma_p = 0,3 \cdot 10^8 \text{ 1/Ohm m}$

$$\delta_n = 4 \cdot 10^{-3} M \approx 4 \text{ mm}$$

For comparison, without the magnetic field the boundary layer thickness [5] $\delta_n = \frac{L}{\sqrt{\text{Re}}} \cong 0,1 \text{ mm}$

The tangential stress τ on the wall washed with the turbulent melt flow will be:

$$\tau = \rho_p v_h' L \frac{dU_p}{dy}, \quad (2)$$

where ρ_p – the melt density, v' – the stirring rate of the melt, L – characteristic mould dimension, $\frac{dU_p}{dy}$ – velocity gradient in the turbulent flow, y – the distance from the wall.

For moulds $v_p' \approx U_p$ and $y \approx \delta_n$.

In this case for $U_p = 3$ m/s, $\delta_n = 4 \cdot 10^{-3}$ m, $\rho_p = 2370$ kg/m³ and $L = 0.1$ m one obtains $\tau = 0.5 \cdot 10^6$ N/m² = $0.5 \cdot 10^2$ N/cm² (5 kg/cm²), that is, the tangential stress value is insufficient for the oxide film removal from the solid aluminum surface, but is sufficient enough for the loss of its stability and involvement into the hydrodynamic flow at the surfaces of the welded busbar details having been melted.

In this case the film is involved into the turbulent flow of the melt, and at welding the busbar and flexible there is no need for the fluxing agents being used.

The thermal flow q_p onto the mould wall, when the turbulent melt flow influences it, equals [6]:

$$q_p = St \rho_p U_p H_p, \quad (3)$$

where St – the Stanton number, $H_p = C_p T_p$ – the melt enthalpy. The Stanton number depends on the melt flow conditions on the wall. In case of the laminar flow when the wall roughness (a) is lower than boundary layer thickness δ_n :

$$St_L = \frac{1}{8} (0,0032 + 0,221 Re^{-0,237}). \quad (4)$$

At turbulent flow

$$St_T = \frac{1}{8(2 \lg \frac{L}{a} + 1,74)^2}. \quad (5)$$

As has been shown above the boundary layer thickness is determined by the magnetic viscosity of the melt and approximately equals 4 mm, that is, the value is many times higher than the busbar surface roughness if the roughness is not made intentionally.

When the Reynolds number Re is 10^6 , St_L is $1.45 \cdot 10^{-3}$ and the melt temperature T_p equals 1200 °C, the heat convective flux onto a smooth busbar surface is $q_p = 7.6 \cdot 10^6$ W/m².

It is possible to increase the thermal flow value by means of the artificial formation of turbulent conditions. The latter implicates the intentional formation of the surface roughness having a size not less than the boundary layer thickness, that is, $a \geq 4$ mm.

For this purpose it is necessary to make crosscut grooves of more than 4 mm in width and depth on the busbar surface and place the flexibles in the mould in the form of steps with a lap (the step length h) of 4 mm, too.

In Fig. 7 there is presented a schematic diagram of the experimental connections of cathodic flexibles to the cathode busbar by means of filling the details being connected in the mould with the overheated melt.

The aluminum was melted in the induction furnace and heated up to the temperature 1200 °C. The melt temperature was controlled with the pyrometer. Filling was made with the ladle 5 placed over the

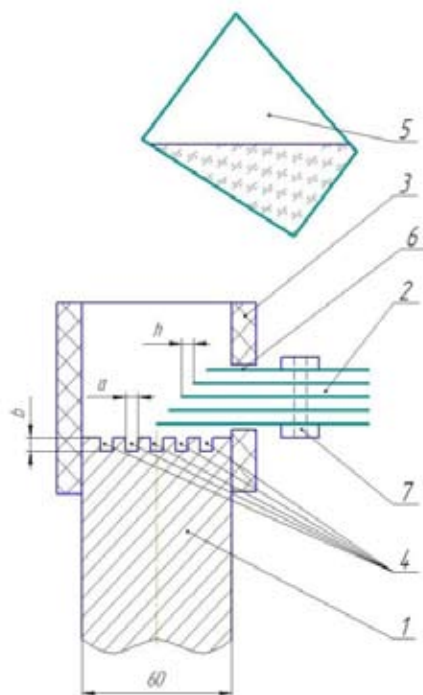

Fig. 7. A schematic diagram of the experimental connections of flexibles to the cathode busbar by means of filling with the overheated melt: 1 – the busbar, 2 – flexibles, 3 – the mould, 4 – milled grooves, 5 – a ladle with the liquid aluminum, 6 – a rectangular opening, 7 – a steel clip

mould at 2530 cm in such a way that the melt should first wash the stepped part of the sheets 2 and then fill the ribbed surface of the busbar 1. The number of the aluminum sheets was 11.

To control the quality of the electric connection there were carried out some measurements of the electrical contact resistance by the 4-probe method. *DC* and *AC* sources were used in the measurements.

In Tables 1 and 2 there are presented the measurement results at *DC* and *AC*.

As can be seen from table 1, at *AC* the transient resistance R of 11 sheets to the cathode busbar connection is $5.53 \pm 0.08 \mu\text{Ohm}$ that equals $60.83 \mu\text{Ohm}$ per sheet. When filling 60 sheets (the standard number of sheets for the cells C8BM) the transient resistance is $1.01 \mu\text{Ohm}$. From table 2 it follows that the transient resistance of 11 sheets at *DC* is $2.14 \mu\text{Ohm}$. And being recalculated for the 60 sheets it is $0.4 \mu\text{Ohm}$ (the standard value of the transient resistance for the cell C8BM is $2.5 \mu\text{Ohm}$).

The work results have been patented [7].

Conclusions

It has been shown that the suggested technology of the cathodic flexible to the cathode busbar connection by means of filling the parts being connected in the mould with the overheated melt provides a quality connection without decreasing the potline current. The usage of the technology gives an opportunity to:

Table 1. Alternating current (AC) results

№	I (A)	U (V)	R (μOhm)
1	240	$132 \cdot 10^{-5}$	5,5
2	300	$168 \cdot 10^{-5}$	5,6
3	480	$265 \cdot 10^{-5}$	5,5

The average value $R = 5.53 \pm 0.08 \mu\text{Ohm}$

Table 2. Direct current (DC) results

№	I (A)	U (V)	R (μOhm)
1	712	0,576	2,16
2	687	0,5506	2,15
3	678	0,5426	2,12

The average value $R = 2.14 \mu\text{Ohm}$

- 1) increase the potline productivity (increasing the metal extraction by current);
- 2) decrease the electric energy loss in the flexible to busbar contact;
- 3) lower the operating costs associated with mounting and dismounting shunts;
- 4) eliminate the use of electric-arc welding.

References

- [1] Галемов Т.Т., Кирко В.И., Петров А.М. и др. Патент РФ № 2343230; 15.03.2007.
- [2] Kirko V.I., Galemov T.T.; Petrov A.M., Vassilyev Yu.V. // Journal of Siberian Federal University. Engineering & Technologies 1 (2008 1).
- [3] Gaman N., Nuvelaar N. G. V. Patent USA № 6.316.125B1; 13.11. 2001.
- [4] Меткалф А. Поверхности раздела металлических композитов. М.: Мир, 1978.
- [5] Кирко И.М., Кирко Г.И. Магнитная гидродинамика несжимаемых сред. Пермь: Изд-во Пермского ун-та, 1980.
- [6] Лойцянский Л.Г. Механика жидкости и газа. М.: Наука, 1973
- [7] Манн В.Н., Чичук Е.Н., Петров А.М., Галемов Т.Т. Патент РФ № 2291916; 22.07.2005.

Соединение алюминиевых деталей ошиновки электролизера «гибкий катодный спуск – катодная шина»

В.И. Кирко^а,

Т.Т. Галемов^б, А.М. Петров^в

*^аКрасноярский государственный педагогический университет
им. В.П. Астафьева,*

Россия 660049, Красноярск, ул. Ады Лебедевой, 89

^бСибирский федеральный университет,

Россия 660041, Красноярск, пр. Свободный, 79

^вЕТС ООО «Объединенная компания»,

Россия 660111, Красноярск, ул. Пограничников, 37

В металлургии, где используются мощные энергетические установки, остро стоит проблема уменьшения потерь при передаче электроэнергии от источника к потребляемому агрегату. Основные потери происходят на контактных соединениях, в частности при передаче электроэнергии от ошиновки алюминиевого электролизера к катодным спускам. В настоящей статье теоретически обосновывается и экспериментально подтверждается возможность соединения ошиновки алюминиевого электролизера к катодным спускам методом заливки бобышки перегретым расплавом алюминия.

Ключевые слова: контактное соединение, электролизер, ошиновка, катодный спуск.
