



CONFORM INSTALLATION STRUCTURAL ELEMENTS DESIGN METHODS

Gorokhov Yury V.¹, Timofeev Viktor N.¹, Belyaev Sergey V.¹, Kirko Vladimir I.^{1,2}, Avdulov A. A.¹,
Konstantinov Igor L.¹, Gubanov Ivan Y.¹, Avdulova Yulia S.¹, Koptseva Natalia P.¹ and Ivanov Alexander G.¹

¹Siberian Federal University, Krasnoyarsk, Russia

²Krasnoyarsk State Pedagogical University named after Victor Astafijev, Krasnoyarsk, Russia

E-Mail: koptseva63@mail.ru

ABSTRACT

The technical features in manufacturing press non-ferrous metal articles have been considered via the Conform continuous pressing. Based on an analysis of different types of press equipment, the absence of a connection between the system for fastening the two-part container fixed part (the shoe) and the working wheel shaft has been revealed as a shortcoming specific to many Conform installations. This does not allow observation of a controlled gap between the shoe and the groove bottom during the operation of the installation, which, in turn, breaks the stable feed of the bar billet into the die. The purpose of this operation is to develop a system for fastening the shoe that ensures the stable continuous metal extrusion process. Meanwhile, the task has been set of creating a tough and strong connection between the shoe and the working wheel shaft with the levers and drafts system that reduces the load of the bearings in the housing posts in which the wheel shaft rotates. As a result, the original technical solution of the Conform installation press unit has been developed. The practical use of the design presented in this work will open up new possibilities for manufacturing pressed metal non-ferrous metal products with a permanently high level of properties.

Keywords: conform installation, non-ferrous metal pressing, continuous extrusion, wheel rim ring groove, two-part container.

INTRODUCTION

The mastery of flexible, compact, energy-saving automated lines designed for manufacturing metal products via continuous pressing methods is promising for the innovative development of metallurgical practices. Among the continuous manufacturing methods of pressed articles of unlimited length described in the works [1-4], the most widespread method is continuous pressing according to the Conform Method, notable for its ease of use, manageability, low energy consumption, high performance and yield, as well as possibilities for achieving high deformation degrees.

The Conform Method is based on the use of a two-part container, whose fastened section known as a shoe, is coupled with a groove (pass) along the circumference of the driving wheel, while inside the shoe are a die and a ring insert with a stop that overlaps the cross section of the wheel pass [5-6]. The pressing pressure is built up by tensions from contact friction between the surface of the driving wheel pass and a billet fed into it so that, as while rolling, they create an active force making the metal advance towards the die. Therefore, the size of the contact area of the billet with the tool predetermines the pressing pressure, the wheel shaft torque, and the installation electric drive capacity, i.e. the power parameters related to the continuous pressing process.

As an illustration of the foregoing, Figure-1 represents the Conform installation for the continuous pressing of non-ferrous metals.

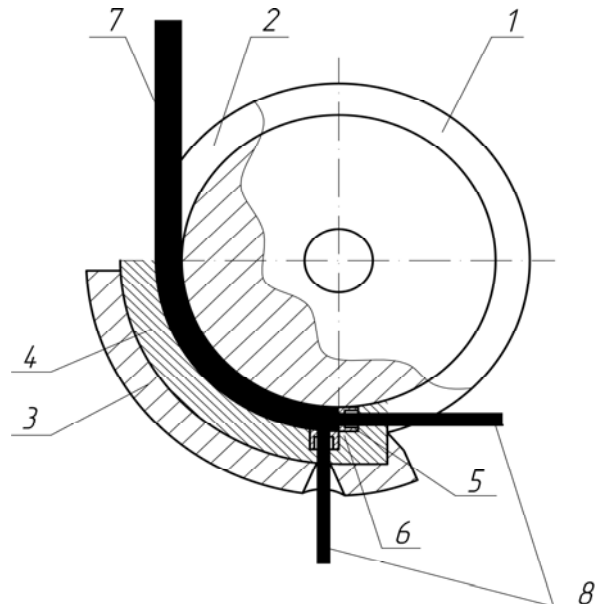

Figure-1. Continuous pressing according to the Conform method: 1- driving wheel; 2 - wheel pass; 3- shoe; 4 - ring insert; 5,6 - dies; 7 - bar billet; 8 - pressed article.

In the Conform continuous pressing, the deformation zone sizes predetermine an amount of pressing pressure built up by specific contact friction forces between the billet and the container mobile part. Therefore, it is necessary to determine a metal contact area with the tool in the course of developing the Conform continuous pressing process. In order to calculate this parameter, it is necessary to set sizes of the cross section of the container in advance, i.e. to determine such a ratio



between the deformation zone's parameters at which the cross section of the billet will be completely covered by shear deformations.

It is reasonable to determine the sizes and forms of a deforming tool for pressing metals according to this scheme in the following sequence [7-8]:

- determining the container section rectangular part height and width ratio at which the surface of its fastened part (the ring insert) is a height boundary of the plastic zone in the pass of the billet that moves along the container to the press the die;
- calculating an entrance angle value of the press die that ensures a minimum amount of pressing pressure;

- calculating the length of the full contact zone of the billet material for the purpose of creating contact friction forces for carrying out the pressing process;
- calculating the value of an angle between the container longitudinal axes and the die channel that ensures a uniform flow of metal along the deformation zone section.

The work [9] presents the optimum values of the ratio of the height of the cross section of the container $h = R_1 - R_2$ to its width b at different values of the friction indicator μ . The values are provided in Table-1.

Table-1. Value of the h/b ration from the friction indicator μ .

μ	0.1	0.2	0.3	0.4	0.5	0.6	0.7	0.8	0.9	1.0
h/b	4.49	2.49	1.66	1.25	1.0	0.83	0.71	0.62	0.55	0.49

It follows from the table that at $\mu = 0.5$, the optimum shape of the cross section of the container is a square, i.e. $R_1 - R_2 = h = b$. It should be noted that in order to prevent any no-plastic zones formation in the corners between the bottom and the walls of the wheel pass, they should be radially coupled.

In order to determine the rational values of the press, the die entrance angle β and the container length that ensure a minimum of friction forces N_0 total capacity and forming energy in the deformation zone [10], the task of finding the entrance angle value is solved β for different friction indicators μ , which are provided in Table-2. These values correspond to the minimum capacity N_0 value.

Table-2. Minimum values N_0 depending on the friction indicator and the die angle.

μ	0.1	0.2	0.3	0.4	0.5	0.6	0.7	0.8	0.9	1.0
N_0 , kW	1,304	1,655	2,044	2,467	2,937	3,448	3,997	4,582	5,219	5,890
β , rad	0,923	1,079	1,167	1,225	1,268	1,301	1,327	1,348	1,366	1,381

The friction forces capacity balance equation solution along the surface of the wheel pass that are necessary for forming metal and overcoming reactive friction forces along the fixed tool provided us a means to determine the length of a contact zone of the bar billet with the container, sufficient for the extrusion of metal

$$\varphi = \frac{2bh \ln\left(\frac{R}{r}\right)}{\sqrt{3}\mu((2h+b)R_2 - bR_1)} \left\{ \frac{2\mu}{\sin \beta} + \frac{1}{27\left(\tan \frac{\beta}{2}\right)^2} \left[\left(12 + 9\left(\tan \frac{\beta}{2}\right)^2 \right)^{\frac{3}{2}} - 12^{\frac{3}{2}} \right] \right\}$$

where R is the radius of the bigger base of the die entrance cone and r is the radius of the smaller base of the die entrance cone.

A number of experiments conducted with the use of a laboratory installation (Figure-2) for the purpose of checking theoretical dependences exhibit satisfactory

into the die hole [11]. This zone is, in turn, equal to the container length depending on the size of the central corner φ drawing together the matching arc of the shoe ring inserts and the wheel pass.

correspondence between the calculated results and the experimental ones.

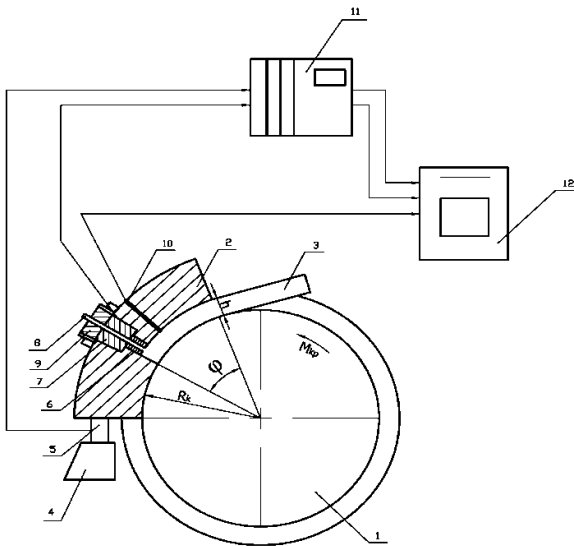

Figure-2. Experimental installation for continuous pressing according to the Conform method: 1- driving wheel with gauge, 2- ring insert, 3- billet, 4- stop, 5 - torque dynamometer, 6- press die, 7- pressure dynamometer, 8- pressed article, 9 - stop nut, 10- thermocouple, 11- amplifier, 12- oscillograph

The research on the continuous pressing design and technological properties with the use of Conform installations conducted by the Siberian Federal University staff [1, 2, 6, 9-11] allowed them to design a number of press units for experimental industrial installations. One of the latest Conform installation models used for processing non-compact aluminum materials [12] is shown in Figure-3 and the press unit structural elements in Figure-4.

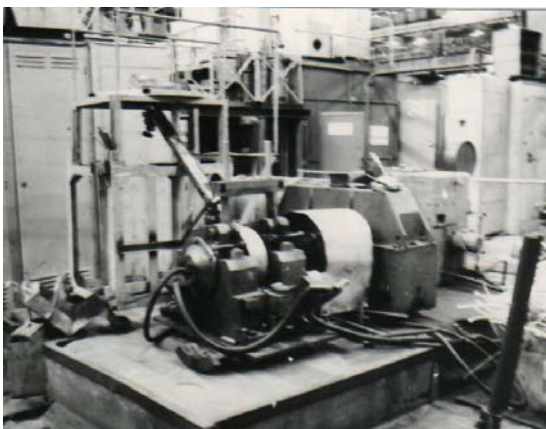
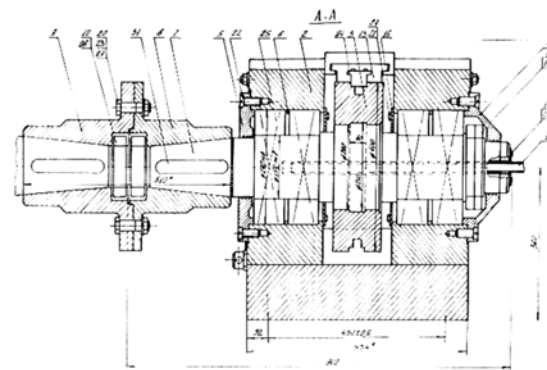
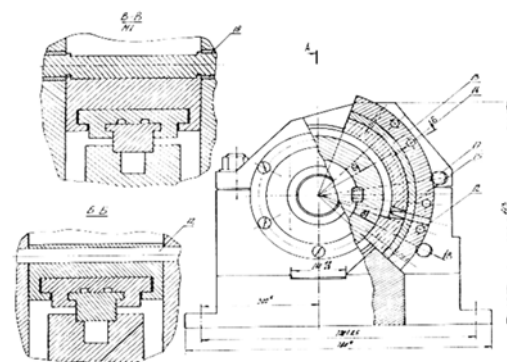

Figure-3. On-site Conform installation for making alloying bars of granular aluminum alloys [12].



(a)



(b)

Figure-4 (a, b). Elements of the conform experimental industrial press unit installation.

The installation consists of a working block that includes the driving wheel with the rectangular section pass, the container fastened part (the shoe) with the fastening and fixing system in a working position, a transfer member, and a direct current motor. The capacity (90 kW) of the engine used for the installation working block drive allows carrying out the continuous metal pressing process with high deformation degrees. In order to increase the torque of the working block shaft, the drive from the electric motor has been made through the reducer with a transfer number of 44.01. The reducer driven shaft is connected with the working unit shaft through a connection sleeve. On the shaft there is a keyed band with a pass made in it. In order to carry out the pressing process of a billet of up to 16 mm in diameter, the band diameter is assumed as equal to 300 mm. The shaft is installed in two posts on rolling bearings.

Figure-5 shows a total view of the Conform installation by Dalian Conform Technical Co., Ltd, [6] the structure of which features no fundamental differences with the above ones and is generally used when extruding profiles with the use of prechambers (Figure-6).



Figure-5. Overview of the Conform installation by Dalian Conform Technical Co., Ltd [6].

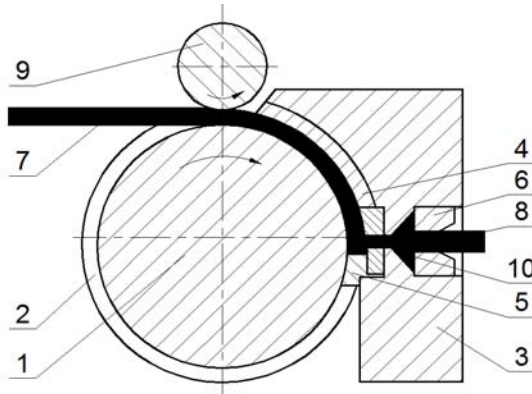

Figure-6. Conform with expandable prechamber: 1 - working wheel, 2- wheel pass, 3- shoe, 4- ring insert, 5- support insert, 6- die, 7- billet, 8- article, 9- pressure roll, 10 - prechamber

The commercial operation of these installations reveals certain shortcomings pertaining to the fastening of the shoe in the radial direction in relation to the wheel via its fastening to the elements of the housing posts. At the same time, the lack of connection between the fastening systems of the shoe and the working wheel shaft reduces the structure's rigidity and results in increased radial loads on the wheel shaft bearings in the housing posts. Furthermore, during the press unit's operation, it is difficult to reliably control the size of the gap between the shoe ring insert and the wheel pass bottom, which, in turn, breaks the stable feed of the bar billet into the die and the uniformity of the outflow of metal into the die hole.

The purpose of this operation is to develop a system for fastening the shoe and fastening it in a working position on the Conform installation in order to carry out stable continuous extrusion of metal into the press die hole.

In order to achieve the envisaged goal, the authors have suggested the design of an installation press unit whose main elements are presented in Figure-7. The drive elements and the Conform experimental installation

working parts have been designed based on the calculations of the extrusion power parameters of aluminum and copper alloys whose values have been determined according to the formulas given in the technical literature [2, 8, 13]. The obtained sizes have been used during the strength calculations of the press unit parts according to the known methods.

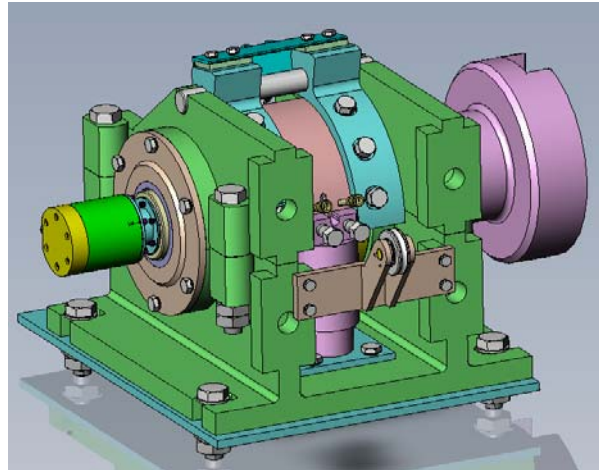

Figure-7. Conform installation press unit to the new fastening system of the shoe.

The figure shows that the system for fastening the shoe is made with due regard to the kinematic properties of the Conform pressing process. For this purpose, the shoe is fixed in an operating position with no impact of the shaft radial beat on the height of the pressing chamber section, which ensures possibilities for regulating the position of the ring insert and the die in the wheel pass, convenience in the case replacing the working tool, and registration of the power and temperature parameters of the metal extrusion process. The shoe features the form of a ring segment whose internal diameter is equal to the diameter of the bushings put on the rolling bearings, which are placed on the shaft on both sides of the wheel band. The internal surface of the shoe borders the bushings of the bearings and fastens them with bolts and between the surfaces of the wheel band and of the shoe there is a certain gap. Thus, the shoe connected with the shaft turns its axis around regardless of the rotation of the working wheel. Meanwhile, the radial force affecting the shoe is transferred to the shaft in the reverse direction in relation to the application of force on the bearings fastening the shaft in the housing posts, which decreases it by an equal-sized value. In order to place the insert and the die in the shoe, there is a dovetail type ring cam slot. The insert as a fourth side of the gauge enters it to some depth, which ensures tightness in the pressing chamber in the radial direction.

Fastening of the shoe in relation to the groove in the tangential direction in relation to the rotation of the wheel is achieved by means of the fixed stop fastened at the housing base and ensuring the stable pressing process. Between the stop and the shoe there is a platform where



the dynamometer is located in order to measure the pressing force.

The shoe with the die and the insert installed in it is fastened to the bushings of the bearings using bolts. The wheel is put into rotation by starting the electric motor. The billet of a certain profile is fed into the gauge, is grasped by it, and is sent to the pressing chamber. The front end of the billet reaches the die, after which it is pressed along the cross section of the chamber, increasing the contract friction force between the walls of the wheel pass and the billet up to the stress necessary for extruding the article into the die channel. The feeding processes of the billet into the chamber, its pressing, and its extrusion take place on a continuous basis during the rotation of the wheel.

For the designed installation, it is planned to carry out a number of experiments for the purposes of enhancing the technology and improving quality of profiles made of non-ferrous metals in light of the development of the last achievements results in this field that are published in the works [14-21].

REFERENCES

- [1] Sidelnikov S.B., Gorokhov Y.V., Belyaev, S.V. 2015. Innovative combined technologies in metal treatment. Journal of Siberian Federal University. Series: Engineering and technologies. 8(2): 185-191.
- [2] Gorokhov Y.V., Sherkunov V.G., Dovzhenko N.N., Belyaev S.V., Dovzhenko, I.N. 2013. Fundamentals of the design of continuous metal pressing processes. Krasnoyarsk, SFU.
- [3] Bauzer M., Zauer G., Zigert K. 2009. Pressing: Reference manual. Moscow, ALYUMSIL MVIT.
- [4] Morozov A.A. 2015. Continuous pressing according to the Conform method. Innovative Science. 12(2): 104-105.
- [5] Goodes I.M. 1975. Continuous Extrusion via the Conform process. Wire Ind, 501: 677.
- [6] Mochalin I.V., Gorokhov Y. V., Belyaev S.V., Gubanov I. Y. 2016. Extrusion of copper busbars during Conform installation with a prechamber. Non-Ferrous Metals. 5: 75-78.
- [7] Gorokhov Y.V., Osipov V.V., Solopko I.V., Katryuk V.P. 2012. Calculation of the temperature fields of the deformation zone during the continuous pressing of metals via the Conform method. Vestnik of MSTU named after G.I. Nosov. 1: 31-34.
- [8] Aborkin A.V., Elkin A.I., Babin D.M. 2015. Features of changing power parameters, temperature, and hydrostatic pressure while continuously pressing non-compact aluminum material. Izvestia of the Higher Education Institutions. Nonferrous metallurgy. 6: 23-29.
- [9] Gorokhov Y.V., Zagirov N.N., Gubanov I.Y. 2004. Calculation of the deformation zone parameters during continuous pressing via the Conform method. Metals. 4: 113-116.
- [10] Sergeev V.M., Sherkunov V.G., Gorokhov Y.V., Gilevich F.S. 1990. Calculation of Optimum Geometry of the Tool during the Continuous Pressing of Metal. Izvestia of the Academy of Sciences of the USSR "Metals. 4: 183-187.
- [11] Gorokhov Y.V., Sergeev V.M., Sherkunov V.G., Gilevich F.S. 1990. Determination of the optimum contact surface of the billet with the tool during continuous metal pressing. Izvestia of the Higher Education Institutions Ferrous metallurgy. 10: 27-29.
- [12] Sherkunov V.G., Gorokhov Y.V., Konstantinov I.L., Katryuk, V.P., Ivanov E.V. 2015. Use of the Conform method for processing shavings of aluminum alloys. Izvestia of the Higher Education Institutions. Nonferrous metallurgy. 3: 60-63.
- [13] Fu-rong CAO Jing-lin WEN Hua DING. 2013. Force analysis and experimental study of the pure aluminum and Al-5%Ti-1%B alloy continuous expansion extrusion forming process. Trans. Nonferrous Met. Soc. China. 23: 201-207.
- [14] Semenova I.P., Polyakov A.V., Raab G.I., Lowe T.C., Valiev R.Z. 2012. The enhanced fatigue properties of ultrafine-grained ti rods processed by ECAP-Conform. Journal Material Sciences. 47(22): 7777-7781.
- [15] Yun X.-B., Yao M.-L., Zhao Y., Yang J.-Y., Li B., Song B.-Y. 2011. The effect of the preventing mould and die structure during continuous extrusion deformation under a large expansion ratio. Suxing Gongcheng Xuebao: Journal of Plasticity Engineering. 18(4): 1-5.
- [16] Zhou T.G., Jiang Z.Y., Wen J.L., Li H., Tieu A.K. 2012. The semi-solid continuous casting-extrusion of AA6201 feed rods. Mater. Sci. Eng. 8: 108-114.
- [17] Kirko V.I. and Sobolenko T.M. 1976. Interaction of particles in high-speed turbulent plasma with the



molten surface of a substrate. Combustion, Explosion, and Shock Waves. 12(6): 807-809.

- [18] Kirko V.I., Dobrosmyslov S. S., Nagibin G. E., and Koptseva N. P. 2016. Electrophysical-mechanical properties of the composite SnO₂-Ag (Semiconductor-metal) ceramic material. ARPJ Journal of Engineering and Applied Sciences. 11(1): 646-651.
- [19] Uskov I.V., Belyaev S.V., Uskov D.I., Gilmanshina T.R., Kirko V.I., Koptseva N.P. 2016. Next-Generatiom Technologies of Manufacturing of Waveguides from Aluminum Alloys. ARPJ Journal of Engineering and Applied Sciences. 11(21): 12367-12370.
- [20] Yuriev Pavel O., Lesiv Elena M., Bezrukikh Alexander I., Belyaev Sergey V., Gubanov Ivan Y., Kirko Vladimir I., Koptseva Natalia P. 2016. Study of Change in the SCMS Strength Properties Depending on the Aqueous-Clay Suspensions Concentration and Muscovites Amount in Its Composition. ARPJ Journal of Engineering and Applied Sciences. 11(15): 9007-9012.
- [21] Koptseva Natalia P. 2015. The current economic situation in Taymyr (the Siberian Arctic) and the prospects of indigenous peoples' traditional economy. Economic Annals-XXI, 9-10: 95-97.