

Frequency-Invariant Beamforming with Real FIR-filters

Alexey A. Erokhin
Institute of Engineering Physics and
Radio Electronics
Siberian Federal University
Krasnoyarsk, Russia
AErokhin@sfu-kras.ru

Evgeniy R. Gafarov
Institute of Engineering Physics and
Radio Electronics
Siberian Federal University
Krasnoyarsk, Russia
slazen@mail.ru

Yury P. Salomatov
Institute of Engineering Physics and
Radio Electronics
Siberian Federal University
Krasnoyarsk, Russia
YSalomatov@sfu-kras.ru

Abstract—Frequency-invariant arrays are widely used in communication systems, audio processing and radar. For this applications wideband beam steering with FIR-filters is required. The paper presents a fixed frequency-invariant beamforming method. Proposed method allows beam steering and it does not require minimizing functions or the Fourier transform. The proposed approach is based on the usage of frequency properties of arrays and allows finding real coefficients of FIR-filters.

Keywords—frequency-invariant beamformer, antenna array, fixed beamforming, FIR-filter, wideband antenna array

I. INTRODUCTION

Frequency-invariant beamforming is widely used in various areas, like wireless communication, radar, audio processing [1]-[4]. Therefore, nowadays frequency-invariant beamforming is researched extensively.

To achieve wideband characteristics of an array, it is necessary to use filters with finite impulse response (FIR-filters) [2], [5] that implement frequency dependent weight vector. Some techniques of frequency-invariant beamforming are based on usage of additional array elements [2], [6]. It should be noted that these methods are equivalent (i.e. in both cases we should to form frequency dependent weight vector). Some of these techniques are based on a minimization problem solution [5], [6] and the other ones are required a Fourier transform [7]-[9].

Frequency-invariant beamforming has been studied quite widely. Circular antenna arrays are used in frequency-invariant beamforming [4]. In [10], beamforming with circular array based on beam pattern approximation is developed. Also, in [11], a circular beamformer based on linear programming with a two-dimensional constraint is proposed. In [12], beamforming technic without temporal filtering is considered. A uniformly spaced three-dimensional array used to achieve frequency-invariant properties. Some authors have proposed a method in which there are no additional elements or FIR-filters. So, in [6], [13] a method which involve decrease a number of array elements by using the concept of co-arrays is considered.

Moreover, adaptive techniques like minimum variance distortionless response (MVDR), linearly constrained minimum variance (LCMV), generalized sidelobe canceler (GSC) and other can be applied to frequency-invariant beamforming [1], [2], [6], [14]-[16]. These entire can provide some advantages but it makes computational complexity very high especially in cases when large antenna arrays are used.

Thus, to prevent this, it is possible to use fixed beamforming techniques. Fixed beamformers are arrays which characteristics are constant and are not dependent on received signal. Such antenna arrays provide lower signal-to-noise ratio in interference environments than adaptive ones. Nevertheless, fixed beamformers are simpler to implement since there is no need for real-time calculations of weight coefficients.

In this paper, we propose a fixed frequency-invariant beamforming technique without solving minimization problem and a Fourier transform. This technique is based on frequency characteristics of the antenna array.

The paper is organized as follows: Section II briefly introduces general principles of wideband beamforming, Section III shows a technic of frequency-invariant beam steering, in Section IV we introduce a proposed method, and Section V includes some concluding remarks about the proposed method.

II. WIDE-BAND BEAMFORMING

Consider a uniform linear antenna array of N isotropic elements. The beam pattern of delay-and-sum beamformer in direction θ at frequency f is

$$F(f, \theta) = \sum_{n=1}^N v_n^* \exp(-j2\pi f \tau_n) = \mathbf{v}^H \mathbf{d}(f, \theta),$$

where $\mathbf{v} = [v_1 \ v_2 \ \dots \ v_N]^T$ is the weight vector, $\mathbf{d}(f, \theta) = [1 \ e^{-j2\pi f \tau_2} \ \dots \ e^{-j2\pi f \tau_N}]^T$ is the array response vector, τ_n is the propagation delay from first element to n^{th} element, which is a function of the angle θ , symbol $(\bullet)^H$ denote Hermitian transpose and bold symbols denote vectors and matrices.

Fig. 1 shows a beam pattern of a narrow-band uniform linear antenna array of $N=16$ elements. The main lobe direction is $\theta_0 = 40^\circ$ at the center frequency of the normalized frequency band $f_0 / f_{\max} = 0.5$. The distance between adjacent elements is the half wavelength at the high frequency. As can be seen from this figure, as the frequency varies the main lobe changes direction. This is the reason that narrow-band beamforming with a constant coefficient for each antenna element will not work effectively in a wideband.

The elements of a weight vector must be different for different frequencies for wideband beamforming. Therefore, we can write its expression as a function of frequency

$$\mathbf{v}(f) = [v_1(f) \ v_2(f) \ \dots \ v_N(f)]^T.$$

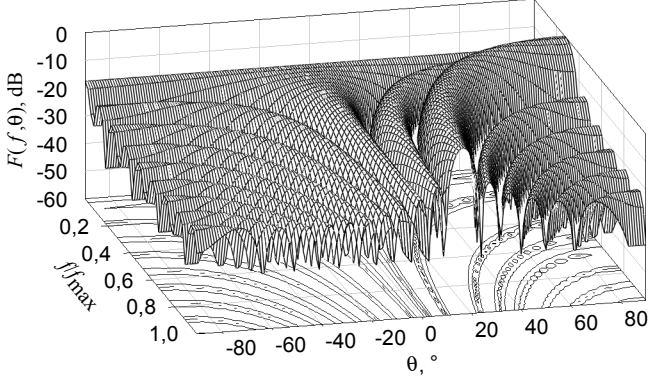

Fig. 1. Beam pattern of a narrowband array.

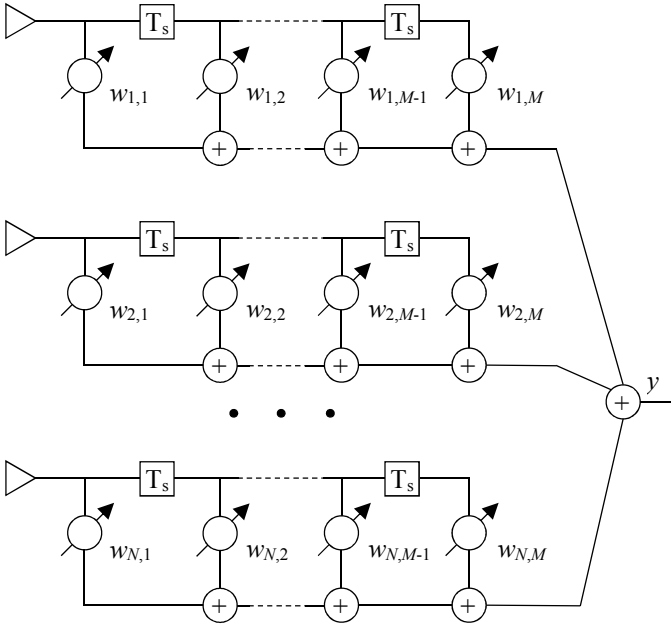

Fig. 2. Wideband antenna array.

Frequency dependent weights in antenna arrays can be obtained using FIR-filters. It perform temporal filtering and form a frequency-dependent weight vector. The scheme of the frequency-invariant beamforming is shown in Fig. 2. In this case, we can write weights in the following form:

$$v_n(f) = \sum_{m=1}^M w_{n,m} \exp\left(-j2\pi m \frac{f}{f_s}\right),$$

where f_s is a sampling rate.

Next, we can write the beam pattern

$$F(f, \theta) = \sum_{n=1}^N \sum_{m=1}^M w_{n,m} \exp(-jm\omega) \exp(-j2\pi f \tau_n),$$

where $\omega = 2\pi f/f_s$ is normalized frequency.

This pattern is a double Fourier transform of the FIR-filter impulse responses. In addition, it is a frequency dependent function. FIR-filters provides the required frequency response.

III. BEAM STEERING WITH FIR-FILTERS

To perform beam steering in antenna array, it is necessary to form a linear phase shift. It can be obtained using FIR-filters with a different slope of the frequency response in each channel of the antenna array. Moreover, the phase shift between the array elements should be such that the beam pattern is steered in one direction at all frequencies of the range.

Impulse response of a bandpass FIR-filter with an arbitrary phase shift described by the following expression [17]

$$w_m = \frac{\sin[(m-\Delta)\omega_2] - \sin[(m-\Delta)\omega_1]}{(m-\Delta)\pi}, \quad (1)$$

where $m=1,2,\dots,M$, M is a filter length (the number of impulse response coefficients), Δ is a positive number, it sets the phase shift, and ω_1, ω_2 are normalized frequencies.

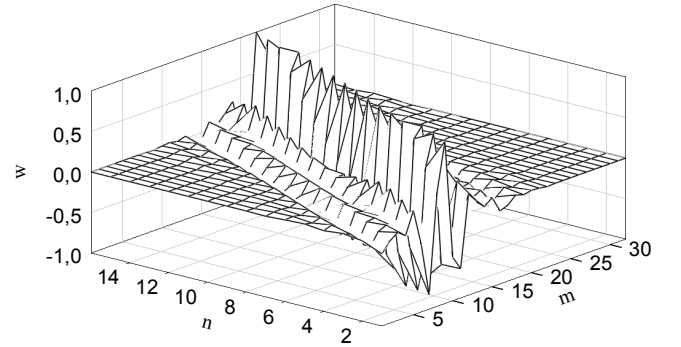

Fig. 3. Impulse responses.

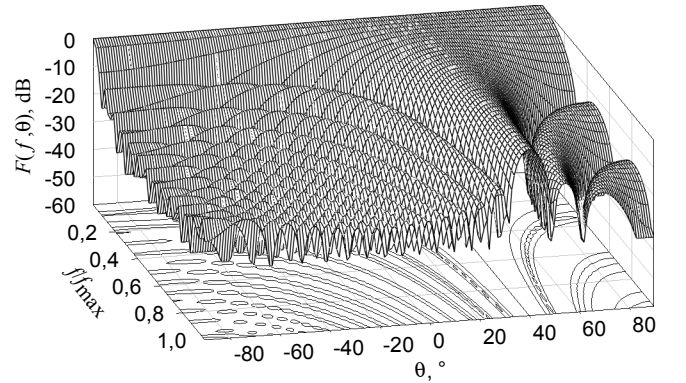

Fig. 4. Frequency-invariant beam steering.

Let us consider a uniform linear antenna array like in a previous section but now we will use FIR-filters with number of coefficients $M = 32$ after each array element. It is possible to set Δ so that main lobe direction is $\theta_0 = 40^\circ$. The coefficients of FIR-filters for beam steering in a wide frequency band are shown in the Fig. 3. It is clear that the impulse responses are very similar but they have different delays. They are caused by main lobe steering.

The steered beam pattern is shown in Fig. 4. Half power beam width on high and low frequencies are different. Main lobe becomes narrow at the high frequency but its direction is constant.

IV. FREQUENCY-INVARIANT BEAM STEERING WITH FIR-FILTERS

To keep a constant beam width in a frequency band, it is necessary to hold the electrical length of the antenna array. When frequency is increasing, it is necessary to reduce the physical size of the antenna array.

Let us write the expression to determine the half-power beam width of the linear antenna array with a uniform amplitude distribution [1]

$$2\theta_{0.5} = \frac{0.886\lambda}{d(N-1)\cos\theta_0},$$

where θ_0 is main lobe direction, d is distance between adjacent elements and λ is wavelength. According to the expression $d(N-1)$ is array length.

From the expression above, it is possible to find the upper cutoff frequencies of FIR-filters necessary to obtain a half-power beam width $2\theta_{0.5}$ for a given number of element n

$$f_n = \frac{0.886c}{d(n-1)2\theta_{0.5}\cos\theta_0},$$

$$\omega_2^n = 2\pi\frac{f_n}{f_s}, \quad (2)$$

where c is propagation velocity of an electromagnetic wave in free space.

Now, we can find the coefficients of FIR-filters for frequency-invariant beamforming using expression (1), taking into account (2). Next, let us write the expression

$$w_{n,m} = \frac{\sin[(m-\Delta)\omega_2^n] - \sin[(m-\Delta)\omega_1]}{(m-\Delta)\pi}. \quad (3)$$

According to these coefficients, the beam pattern has a constant half-power beam width and it can be steered in a wide frequency range.

Fig. 5 shows the coefficients of FIR-filters for frequency-invariant beamforming. As in the previous example we set the number of elements $N=16$ and number of coefficients for each filter is $M=32$, main lobe direction is $\theta_0 = 40^\circ$. In this case, we set half-power beam width $2\theta_{0.5} = 25^\circ$. The maxima of the impulse responses are shifted relative to each other, it ensures a constant phase shift in a frequency range.

Fig. 6 shows the frequency responses of FIR-filters. As the frequency increases, the actual size of the antenna array is decrease, i.e. the ‘‘active’’ region of the array decreases (the physical size of the antenna decreases), since it is necessary to maintain a constant beam width. At low frequencies, most of the frequency responses have almost the same amplitude, since the antenna elements are located too often for these

frequencies. At high frequencies, the active zone contains a smaller part of the frequency responses with high gain. Thus, both at high and at low frequencies, the aperture of the antenna array is used inefficiently. This is the result of a frequency-invariant beamforming.

Fig. 7 shows the resulting beam pattern, it has frequency-independent properties. According to the frequency responses shown in Fig. 6, at low frequencies, main lobe has very large beam width.

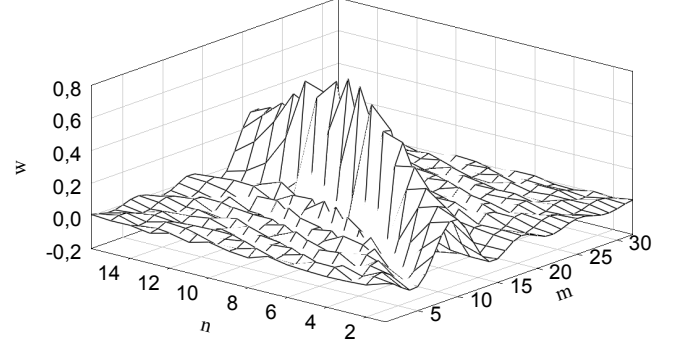

Fig. 5. Impulse responses for frequency-invariant beamforming.

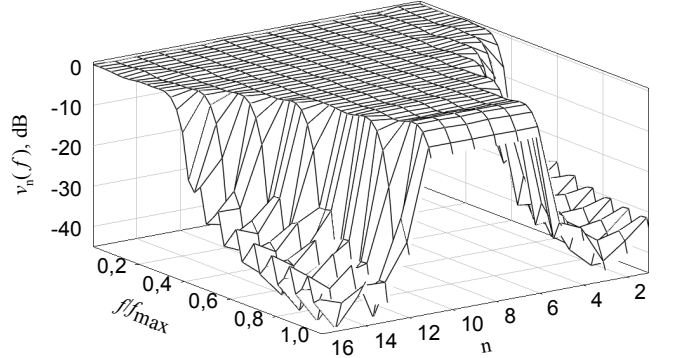

Fig. 6. FIR frequency responses.

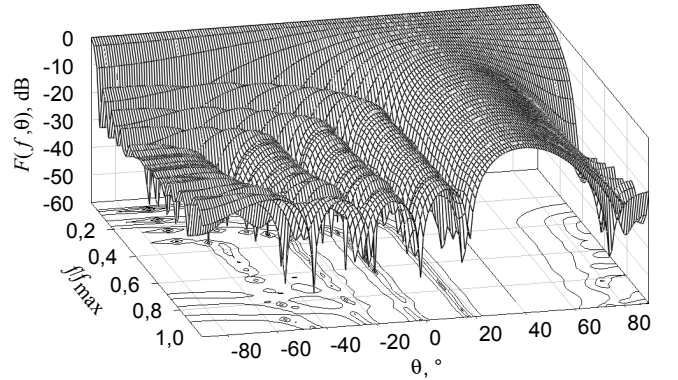

Fig. 7. Frequency-invariant beamforming.

V. CONCLUSION

A simple design method for fixed frequency-invariant beamforming has been proposed. This method does not require complex computations such as solving a minimization problem or employing a Fourier transform. It is very simple to use, since it is required to perform calculations using only two formulas (2) and (3). This method allows finding real coefficients of FIR-filters.

The proposed method is based on an array frequency properties, i.e. half-power beam width depends on array length. As a frequency is increasing, a beam width is decreasing. To prevent this, it is necessary to decrease an array length. Then we can obtain a constant beam width and side lobe level in a wide frequency range. It should be noted that other frequency-invariant technics are based on the same principle.

Moreover, proposed method can be applied to an antenna arrays with any number of elements or can be generalized to multi-dimensional arrays.

REFERENCES

- [1] H. L. Van Trees, *Optimum Array Processing, Part IV of Detection, Estimation, and Modulation Theory*. New York, USA: John Wiley & Sons Inc., 2002.
- [2] W. Liu and S. Weiss, *Wideband Beamforming: Concepts and Techniques*. Chichester, U.K.: Wiley, 2010.
- [3] Tuan Do-Hong, F. Demmel, and P. Russer, "Wideband direction-of-arrival estimation using frequency-domain frequency-invariant beamformers: an analysis of performance," *IEEE Microwave and Wireless Components Lett.*, vol. 14, no. 8, pp. 383–385, Aug. 2004, doi: 10.1109/LMWC.2004.832633.
- [4] G. Huang, J. Benesty, and Jingdong Chen, "On the Design of Frequency-Invariant Beampatterns With Uniform Circular Microphone Arrays," *IEEE/ACM Trans. on Audio, Speech, and Language Processing*, vol. 25, no. 5, pp. 1140–1153, May 2017, doi: 10.1109/TASLP.2017.2689681.
- [5] S. Yan, Y. Ma, "Design of FIR beamformer with frequency invariant patterns via jointly optimizing spatial and frequency responses," in *Proc. IEEE Int. Conf. on Acoustics, Speech, and Signal Processing*, Mar. 2005, pp. IV/789–IV/792, doi: 10.1109/ICASSP.2005.1416127.
- [6] P. Pal, P. P. Vaidyanathan, "Frequency invariant MVDR beamforming without filters and implementation using MIMO radar," in *IEEE Int. Conf. on Acoustics, Speech and Signal Processing*, Apr. 2009, pp. 2081–2084, doi: 10.1109/ICASSP.2009.4960025.
- [7] T. Sekiguchi and Y. Karasawa, "Wideband beamspace adaptive array utilizing FIR fan filters for multibeam forming," *IEEE Trans. on Signal Processing*, vol. 48, no. 1, pp. 277–284, Jan. 2000, doi: 10.1109/78.815503.
- [8] W. Liu, S. Weiss, "Design of Frequency Invariant Beamformers for Broadband Arrays," *IEEE Trans. on Signal Processing*, vol. 56, no. 2, pp. 855–860, Feb. 2008. doi: 10.1109/TSP.2007.907872.
- [9] S. Weiss ; M. Hadley ; J. Wilcox, "Implementation of a Flexible Frequency-Invariant Broadband Beamformer Based on Fourier Properties," in *2017 Sensor Signal Processing for Defence Conf.*, Dec. 2017, pp. 1–5, doi: 10.1109/SSPD.2017.8233239.
- [10] G. Huang, J. Chen, and J. Benesty, "Insights Into Frequency-Invariant Beamforming With Concentric Circular Microphone Arrays," *IEEE/ACM Trans. on Audio, Speech, and Language Processing*, vol. 26, no. 12, pp. 2305–2318, Aug. 2018, doi: 10.1109/TASLP.2018.2862826.
- [11] X. Zhang, W. Ser, and K. Muralidhar, "Uniform circular broadband beamformer with selective frequency and spatial invariant region," in *IEEE Int. Symp. on Circuits and Systems*, Jun. 2009, pp. 2201–2204, doi: 10.1109/ISCAS.2009.5118234.
- [12] W. Liu, D. C. McLernon, and M. Ghogho, "Frequency Invariant Beamforming Without Tapped Delay-Lines," in *2007 IEEE Int. Conf. on Acoustics, Speech and Signal Processing*, Jun. 2007, pp. II-997–II-1000, doi: 10.1109/ICASSP.2007.366406.
- [13] P. Pal and P. P. Vaidyanathan, "Efficient frequency invariant beamforming using virtual arrays," in *Record of the Forty Fourth Asilomar Conf. on Signals, Systems and Computers*, Apr. 2011, pp. 1097–1101, doi: 10.1109/ACSSC.2010.5757573.
- [14] H. H. Chen, S. C. Chan, and K. L. Ho, "Adaptive Beamforming Using Frequency Invariant Uniform Concentric Circular Arrays," *IEEE Trans. on Circuits and Systems I: Regular Papers*, vol. 54, no. 9, pp. 1938–1949, Sep. 2007, doi: 10.1109/TCSI.2007.904648.
- [15] D.B. Ward, R.A. Kennedy, and R.C. Williamson, "An adaptive algorithm for broadband frequency invariant beamforming," in *IEEE Int. Conf. on Acoustics, Speech, and Signal Processing*, Apr. 1997, pp. 3737–3740, doi: 10.1109/ICASSP.1997.604682.
- [16] W. Liu, S. Weiss, and L. Hanzo, "A generalized sidelobe canceller employing two-dimensional frequency Invariant filters," *IEEE Trans. on Antennas and Propag.*, vol. 53, no. 7, pp. 2339–2343, Jul. 2005, doi: 10.1109/TAP.2005.850759.
- [17] A. V. Oppenheim and R. W. Schaffer, *Discrete-Time Signal Processing*. Pearson, 2010.